

Nordisk Dialogkonference

om nye forretningsmodeller
som understøtter elektrificeringen
af erhvervstransporten

Interreg



Co-funded by
the European Union

Öresund-Kattegat-Skagerrak

Copenhagen **Electric**



Program

- 10.00 - 10.10 Dialogkonferencen åbnes v/ Christina Bech Godskesen Andersen, Copenhagen Electric
- 10.10 - 10.30 Fremtidens Transport: Inspiration til at opdage nye forretningsmodeller
v/ Forretningsudvikler & Inspirator Pernille Lytzen, tGrace
- 10.30 - 11.15 Virksomhederne præsenterer deres forretningsmodeller
- 11.15 - 11.30 Pause med dialog ved standene
- 11.30 - 11.45 Hvordan kan vi understøtte elektrificeringen af erhvervstransporten med andre løsninger allerede i dag v/ Joakim Nilsson, Volvo Trucks
- 11.45 - 12.30 Virksomhederne præsenterer deres forretningsmodeller
- 12.30 - 13.30 Frokost & dialog ved standene
- 13.30 - 13.40 Hvordan tænker vi ud af boksen for at få mere grøn omstilling for pengene?
v/ Niels Kristian Holm, Lantmännen Schulstad
- 13.40 - 14.30 Virksomhederne præsenterer deres forretningsmodeller
- 14.30 - 14.35 Opsamling & tak for i dag
v/ Christina Bech Godskesen Andersen, Copenhagen Electric / Region Hovedstaden
- 14.35 - 15.00 Kaffe & kage med dialog ved standene

Dialogkonferencen åbnes

Nordisk dialogkonference om nye forretningsmodeller som understøtter elektrificeringen af erhvervstransporten

v/ Christina Bech Godskesen Andersen, Copenhagen Electric / Region Hovedstaden

10.00-10.10



Transport er ikke alt... MEN DER ER TRANSPORT I ALT

Interreg



Co-funded by
the European Union

Öresund-Kattegat-Skagerrak

SCALE - SCAndinavian road Logistics Electrified

Transporten kender ingen grænser og derfor er det vigtigt med løsninger på tværs af grænser!

(kommuner – regioner – stater)

Copenhagen Electric

Et regionalt VIDENSCENTER for e-mobilitet

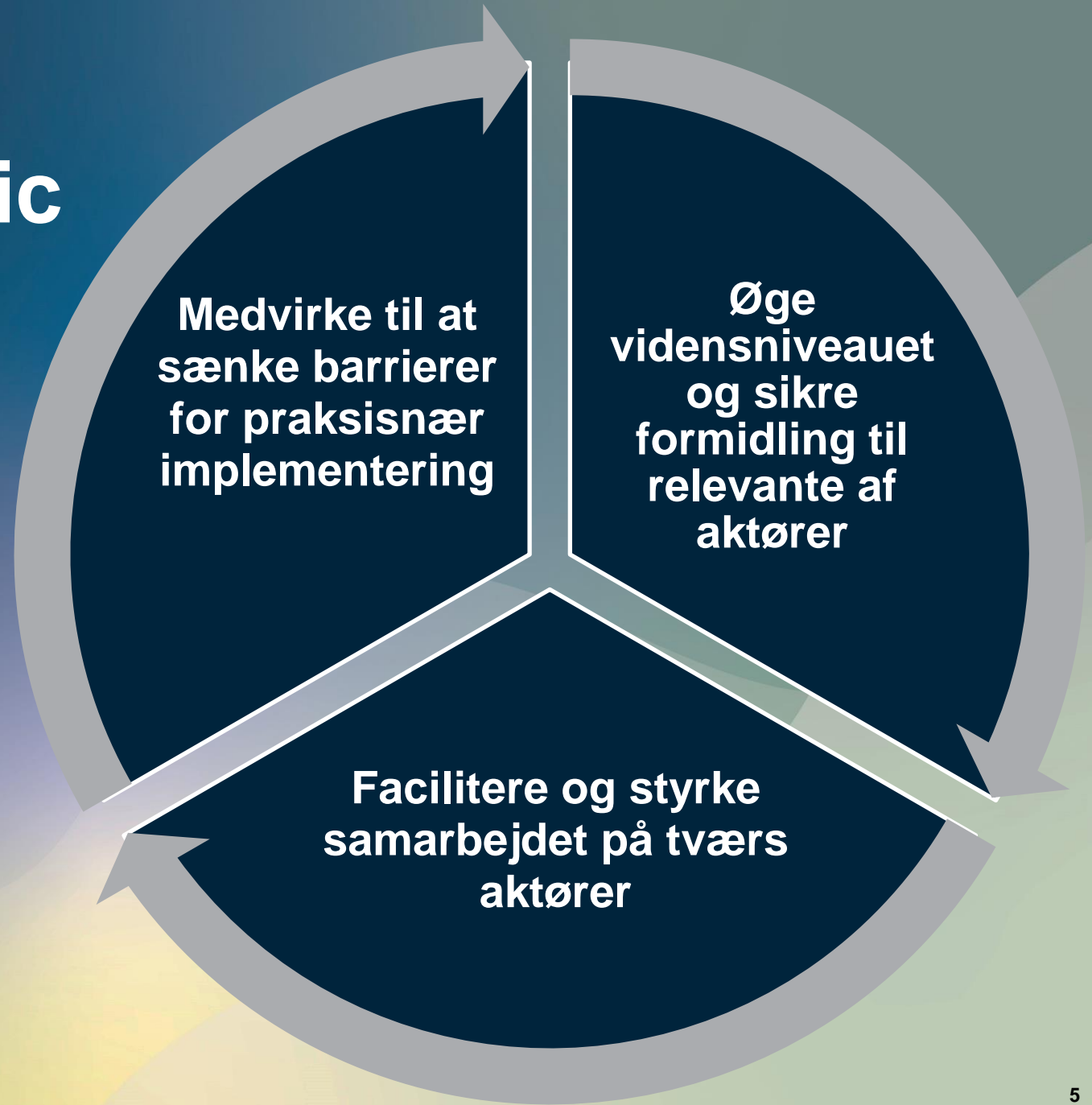

Målsætning...

Grøn omstilling af transporten er en bunden opgave!

- Nationalt mål om **70 %** CO2 reduktion i 2030 (i Danmark)
- Godstransporten står for ca. **10%** af den samlede udledningen (i Danmark) Stigende

mod **20 % i 2030**

Teknologi...

- **Nødvendig** – men dyr (lidt endnu)
- **Ændrer hele økosystemet** omkring transport

- Stiller **krav til nytænkning**

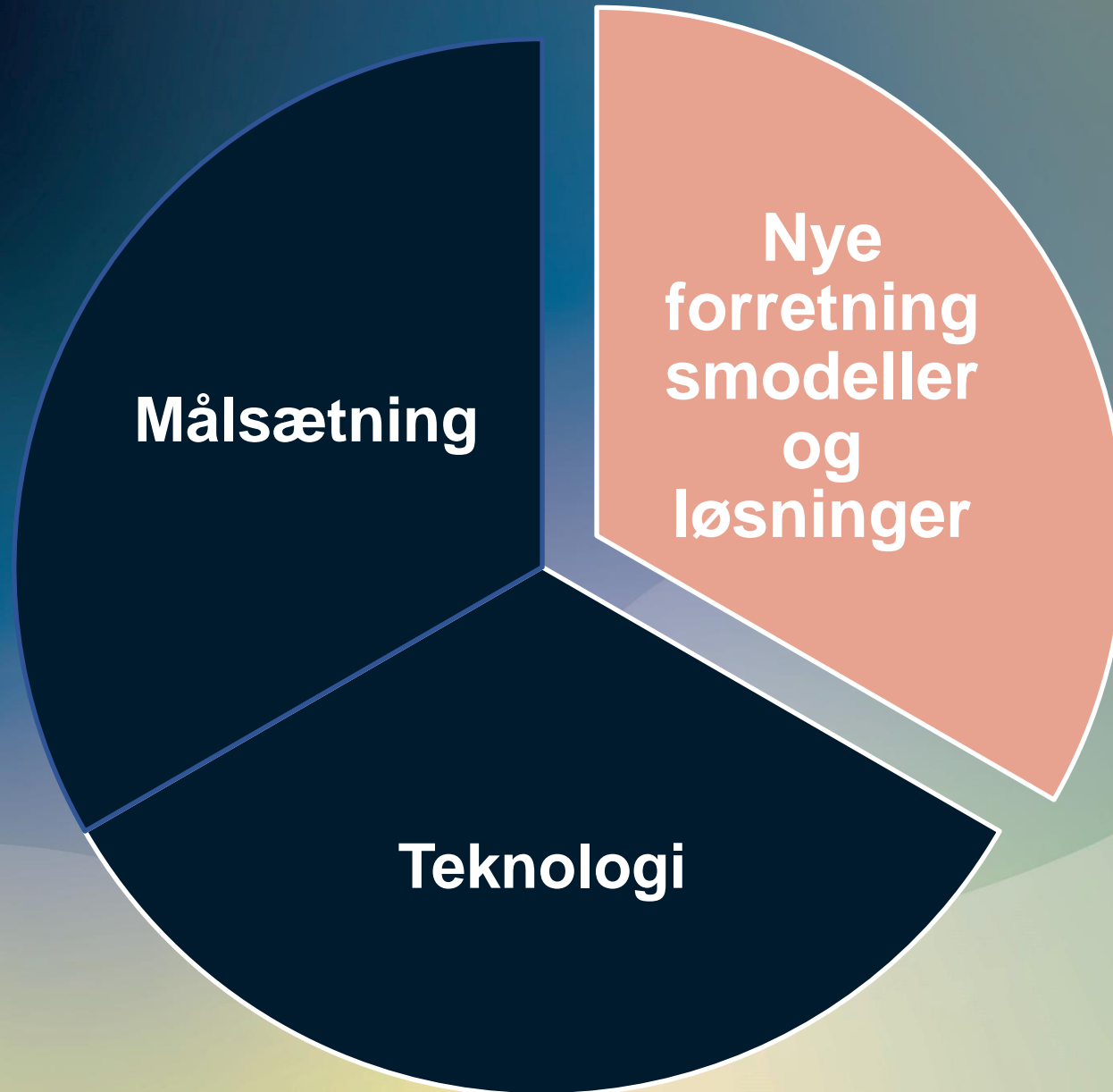

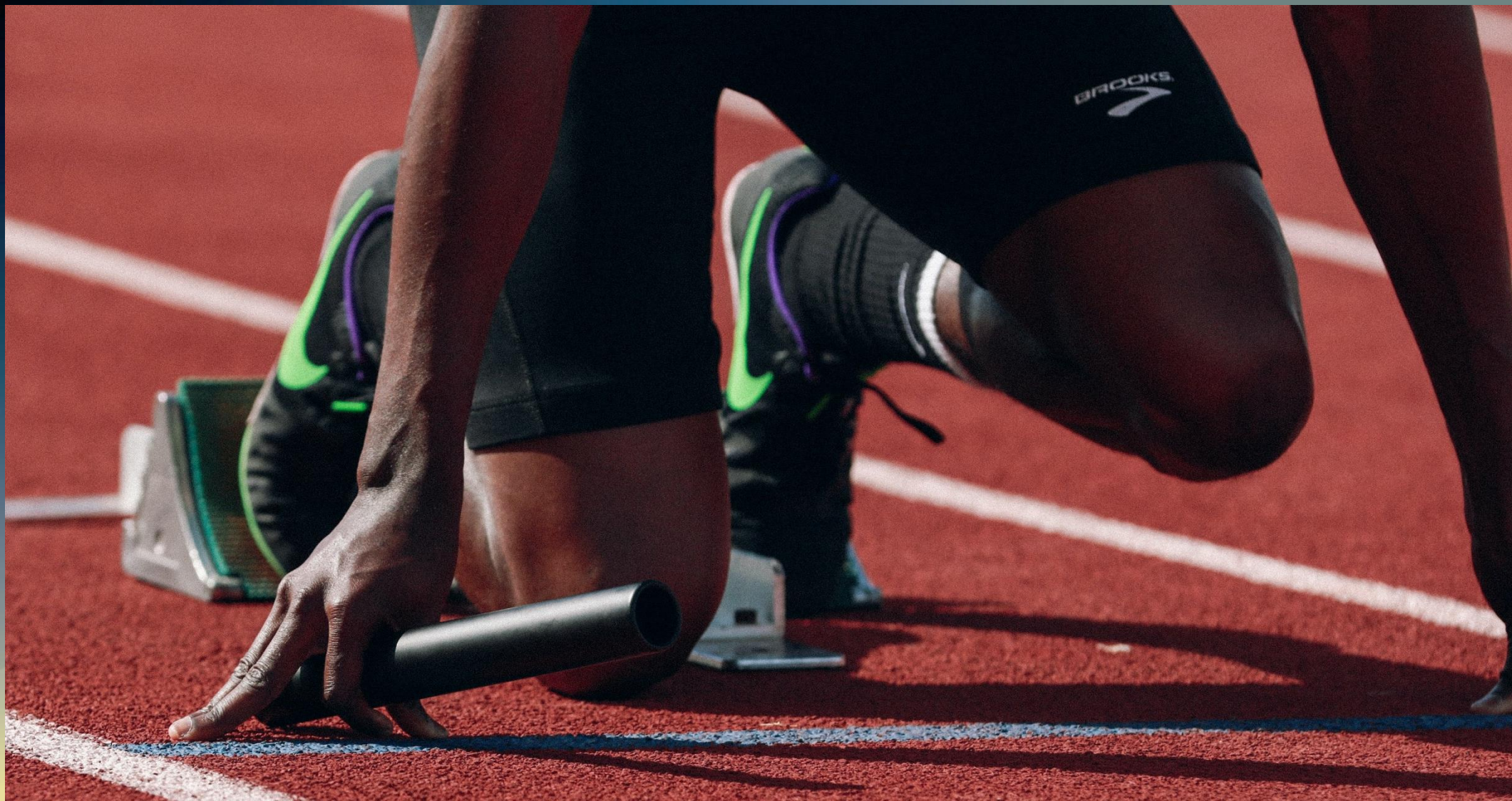

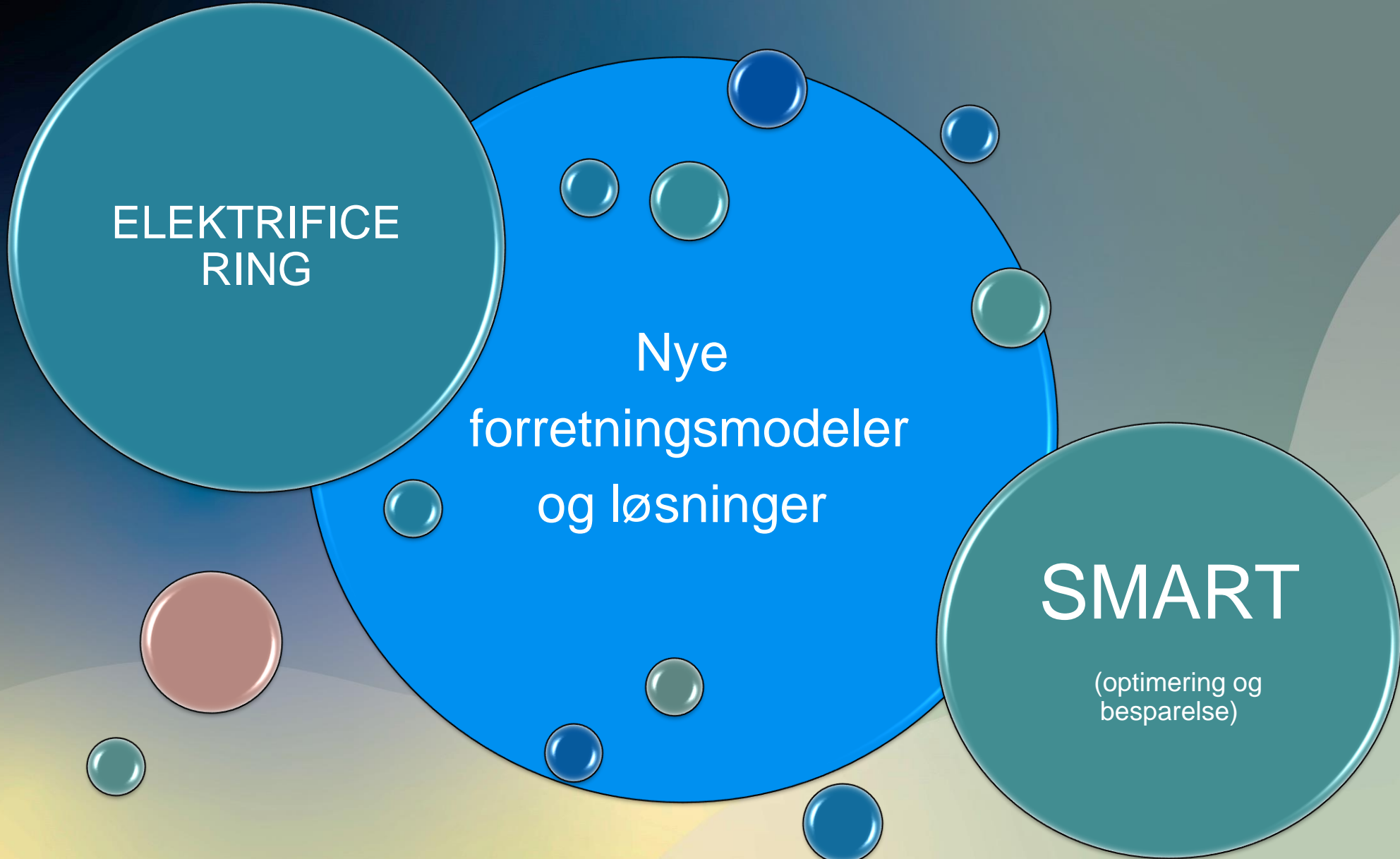

DAGENS PROGRAM

10.00 **Åbning af dialogkonferencen**

10.10 **Hvorfor er nye forretningsmodeller vigtige?**

v/ Pernille Lytzen – tGrace -
Forretningsudvikler og inspirator

10.30 **Virksomhederne præsenterer deres nye forretningsmodeller og løsninger**

1: Eldrift v/ Jon Arne Hammersmark

2: Designwerk v/ Jens Bahrmann

3: **Dora Nordic** v/ Rikke Høyer

11.15 PAUSE – dialog ved standene

11.30 **Hvordan kan vi understøtte elektrificeringen af erhvervstransporten med andre løsninger allerede i dag?**

Samtale med Joakim Nilsson,
Volvo Trucks

11.40 **Virksomhederne præsenterer deres nye forretningsmodeller og løsninger**

1: CargoTruckExchange v/ Henrik Larsen

2: **Banke** v/ Janick Cordt Hansen

3: Uptimus v/Magnus Bergkvist Sørensen

12:30 FROKOST – dialog ved standene

13.30 **Hvordan tænker vi ud af boksen for at få mere grøn omstilling for pengene**

Samtale med Niels Kristian Holm,
Lantmännen Schulstad

13.40 **Virksomhederne præsenterer deres nye forretningsmodeller og løsninger**

1: **Nerve Smart Systems** v/ Jens Raarup og George Ivanovic

2: Vailumina v/ Pontus Frohde og Patrik Lindergren

3: Einride v/Carl Ceder

14.30 Kaffe og kage – dialog ved standene

15.00 Konferencen slutter – tak for i dag



Fremtidens Transport: Inspiration til at opdage nye forretningsmodeller

v/ Forretningsudvikler & Inspirator Pernille Lytzen, tGrace

10.10-10.30



Fremtidens Transport

Og hvordan den kan inspirere os til at opdage nye forretningsmodeller

Nordisk Dialogkonference d. 29.03.2023

Pernille Lytzen, founder tGrace



HVEM TALER?

UDDANNELSE



Copenhagen Business School

B.Sc. & M.Sc. i Erhvervsøkonomi & Psykologi

PROFESSIONEL BAGGRUND

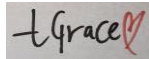

Founder & Owner



Business Development Director & del af MT



Innovation & Business Design Manager



Project Manager, Business Development



Consultant

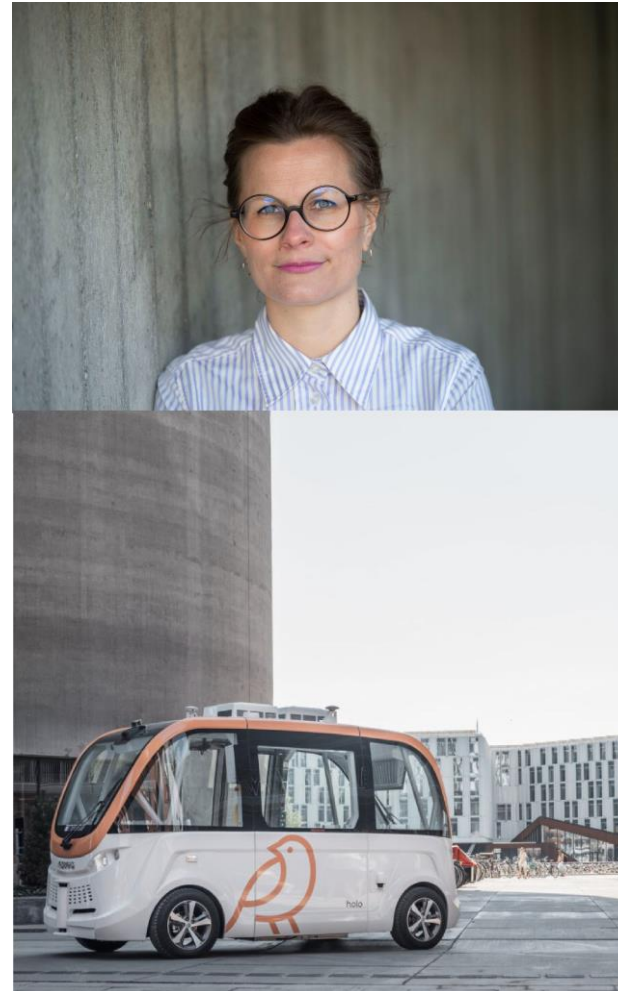

DE NÆSTE 20 MIN.

FLYVENDE BILER ER IKKE LÆNGERE SCI-FI

2 SCENARIER: OM 5 & 10 år

HVAD KAN VI BRUGE DET TIL I DAG?

LIDT OM ET SIDESPEJL

FLYVENDE BILER ER IKKE LÆNGERE SCI-FI

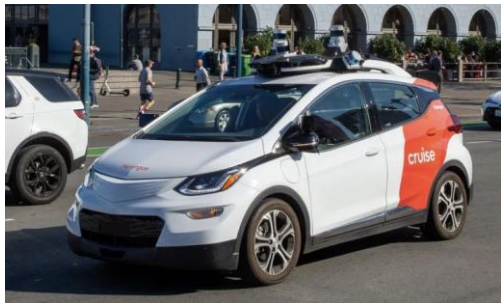

DE NÆSTE 5 ÅR



Assist systemer baner vejen for fuldt selvkørende



Dronerne får større udbredelse



Forbedret LIDAR teknologi



Selvkørende fragt vinder hurtigt frem



Flere og flere "ægte" selvkørende km

Typegodkendelser & EU lovgivning

OEMs på banen

Partnerskaber på tværs

Mobilitet på tværs af domæner

OM 10 ÅR

ELEKTRISK, AUTONOM, DØR-TIL-DØR, ON DEMAND. MINDRE, BLANDET FLÅDE, DER LØSER OPGAVER PÅ TVÆRS.

NYT ØKOSYSTEM.



HVORDAN KAN FREMTIDENS TEKNOLOGIER HJÆLPE MED NYE FORRETNINGSMODELLER I DAG?

NOGLE AF KODEORDENE:

- Multimodalitet
- Meget mindre flåde
- Nyt økosystem rundt omkring transport
- Markeder der smelter sammen og påvirker hinanden
- ..og dermed nye samarbejdskonstellationer
- Helt nye markeder & nye services
- Bundling af services

FÆLLES FOR ALLE DE NYE TEKNOLOGIER:

- **Der er flere forhindringer end åbne veje**
- Problem solving: Vær bevidst om, hvilket problem du faktisk prøver at løse.
- MVP tilgang, hurtige prototyper, **hurtig TEST**, hurtig tilretning
- Kig udenfor din egen branche og logik



Idé-redskab #1: LIST REGLERNE - OG BRYD DEM



+ Grace ♡

Virksomhederne præsenterer deres forretningsmodeller

10.30-11.15



Eldrift

v/ Jon Arne Hammersmark

10.30-10.45



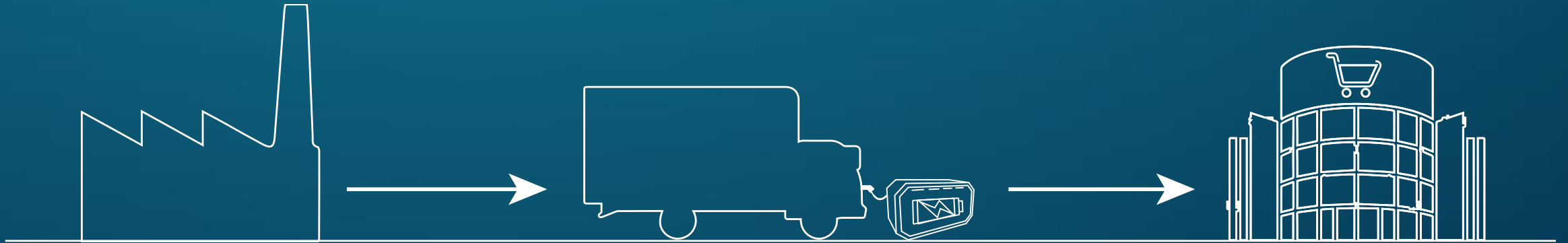

Rapid chargers for locations with minimal electrical infrastructure.

**EL
DRIFT**

www.eldrift.no

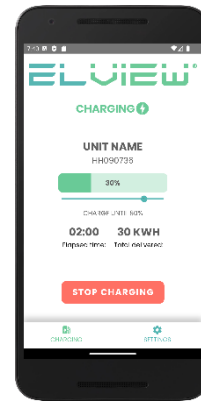
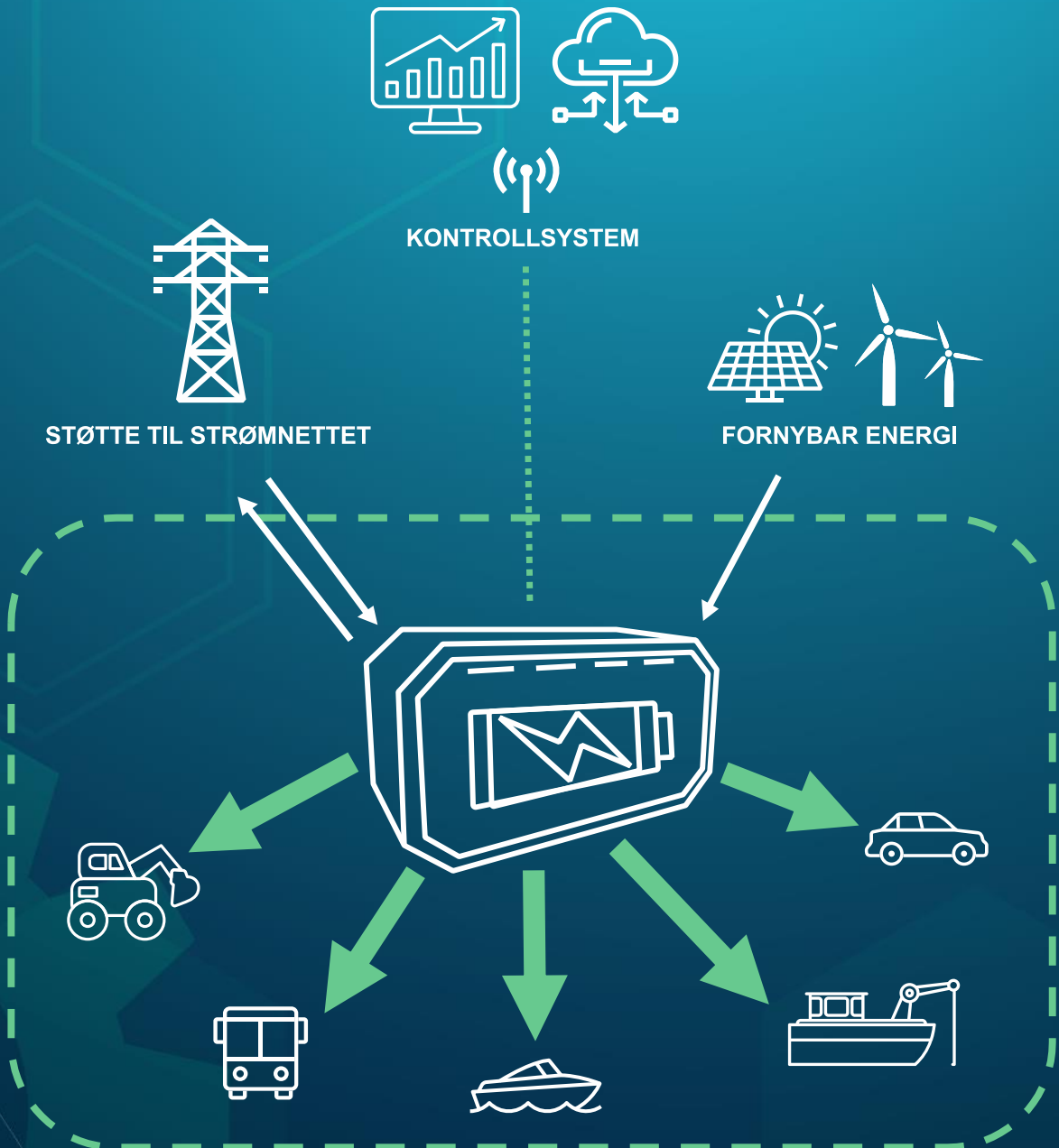

«De mest kostnads-
effektive og bærekraftige
batteriener i verden.»



EL
DRIFT

ELCHARGE™

Mobil hurtiglader med batteribank

- Lynlading uten tilgang til strøm
 - Lavere belastning på strømnettet med batteri
- *Vi tjener ikke penger når vi står i ro og vi har fått en løsning som holder liv i maskinene en hel arbeidsdag.*



- 225 kWh
- 150 kW
- 2,4 tonn
- 5 m³



EL DRIFT



- 225 kWh
- 90 kW
- 2,1 tonn
- 9 m³



Sørlandslisten i Grimstad (Foto: Greenstat)

ELSTORE™

Mobilt eller stasjonært energilager

- Markedsledende batterikapasitet
- Batterimodulene er bygget på samme standard som i en elbil
- Kan avlaste strømnett på belastede tidspunkt
- 225 kWh batteriet reduserer produksjons-utslippet med 16,5 tonn CO₂ i forhold til nye batterier



EL DRIFT

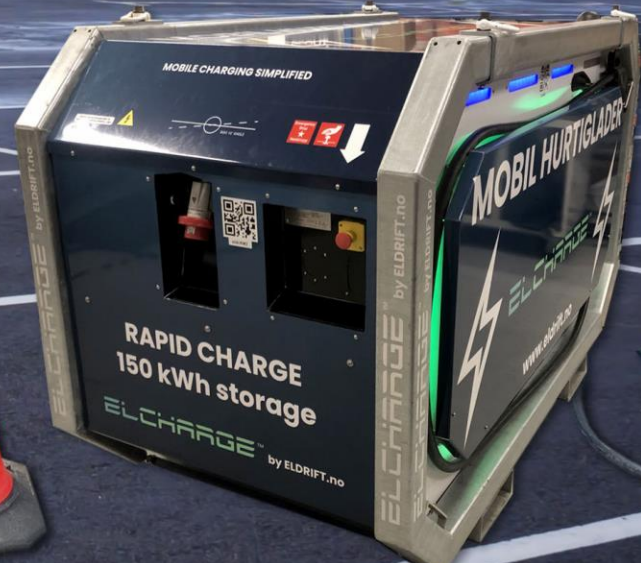

Rapid chargers for locations with minimal electrical infrastructure.



www.eldrift.no

Designwerk v/ Jens Bahrmann

10.45-11.00



An aerial photograph of a winding asphalt road through a mountain valley. The terrain is rugged and rocky, with sparse vegetation. The road curves through the valley, leading towards a mountain range in the distance. The sky is overcast.

DW DESIGN
WERK

Your expert for electromobility

Jens Bahrmann
Key Account Manager Europe North

Member of the Volvo Group

Electromobility from a single source

DESIGNWERK



Chargers



E-trucks



Battery systems



Engineering

Firsts



First all-electric car carrier for Galliker Transport Logistics.



First long-distance trucks with 900 kWh for Galliker & Friderici Transport.



World record for the longest distance driven by an e-truck without charging (1099 km).



First all-electric concrete mixer for Lafarge / Holcim.

Designwerk High Cab Semi 6x2T

- + Drive power 500 kW / 680 hp
- + Unique electric range with up to 1000 kWh battery capacity
- + Short service lives due to 350 kW charging power; charged to 80% SoC in 0.6 hrs.
- + Five times higher efficiency than a diesel equivalent
- + continuously variable transmission ensures smooth starting, and the unique recuperation pedal ensures maximum driving comfort
- + Multi-length version available in selected countries



E-trucks for every application

Advantages

- + Ideal for operation in stop-and-go (high settlement density)
- + High efficiency
- + Energy recovery thanks to recuperation
- + Reduction of noise for employees & population
- + Improvement of occupational safety
- + Ideal for topographically challenging terrain
- + Elimination of local nitrogen oxides, CO2 emissions, particulate matter
- + No loss of performance when using auxiliary units
- + Country-specific funding initiatives



Technology

Specifications

- Volvo or Mercedes-Benz base chassis
- Drive power 500 kW / 680 hp
- 1-speed gearbox gear ratio
- Battery type Lithium-Ion (NMC)
- System voltage 400 V
- Charging options on-board up to 44 kW AC, off-board up to 350 kW DC (CCS Type 2; 800V)
- Battery capacity 170 kWh to 900 kWh

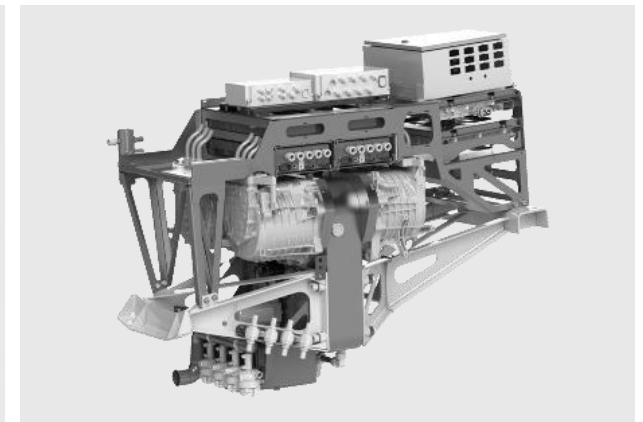
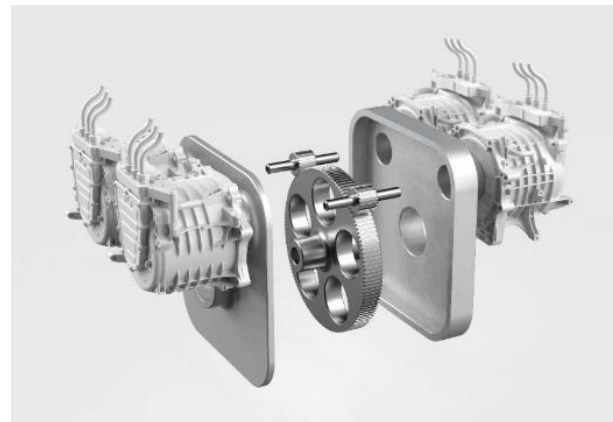
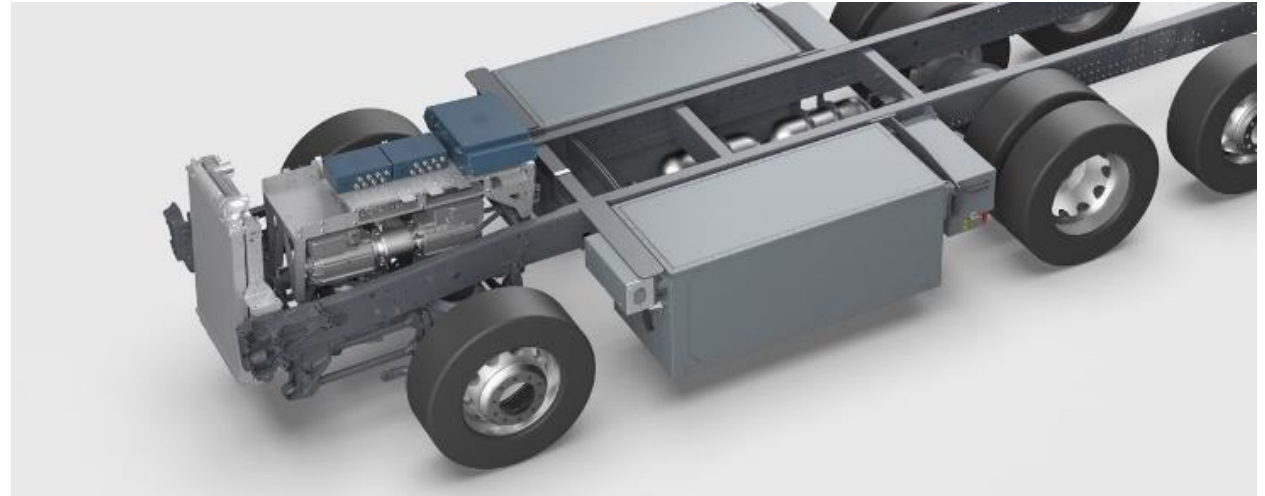

Holistic customer solutions

- + Many years of experience
- + In daily use since 2017
- + Outstanding autonomy
- + Advantage of 350 kWh CCS charging technology



More than 150 vehicles in use

Until November 2022, our customers drove **4,270,418** kilometres.



Range

Realistic range 500 km in daily operation

- Winterthur – Julier Pass and back
- 430 km, 1858 meters ascent
- Maximum battery capacity: 900 kWh
- Up to 14% recuperation



900 kWh
BATTERIE-KAPAZITÄT
+21 Tonnen
ZULADUNG



900 kWh
BATTERIE-KAPAZITÄT
+36 Tonnen
ZULADUNG

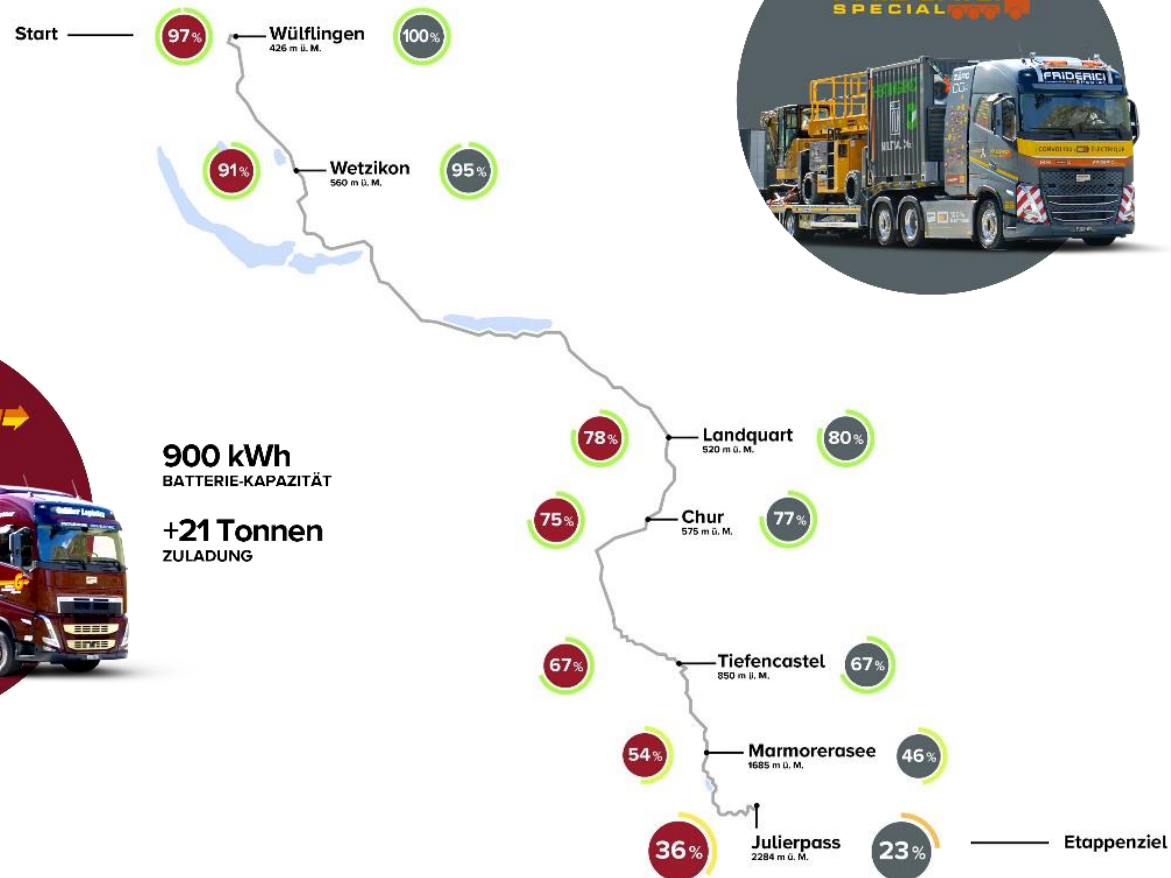

Permissible train length



High-voltage battery systems



Battery construction

System

- + Modules from the automotive industry
- + Housing with thermal insulation
- + Cooling plates
- + Battery Management System



Mobile DC fast chargers for electric vehicles



Our models



Mobile Charger
22 – 450



Mobile Charger
44 – 450



Mobile Charger
88 – 450

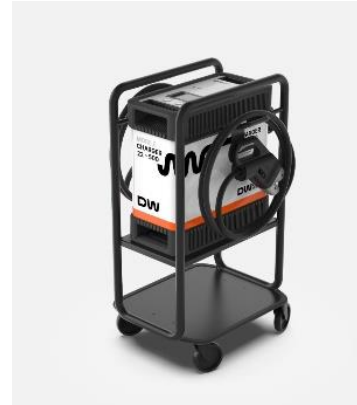

Mobile Charger
22 – 500

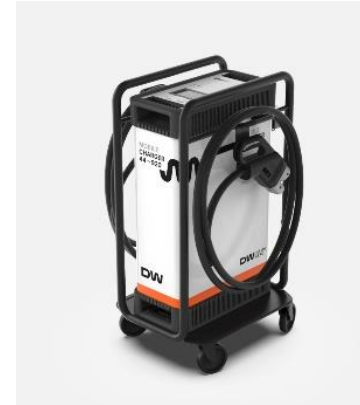

Mobile Charger
44 – 920

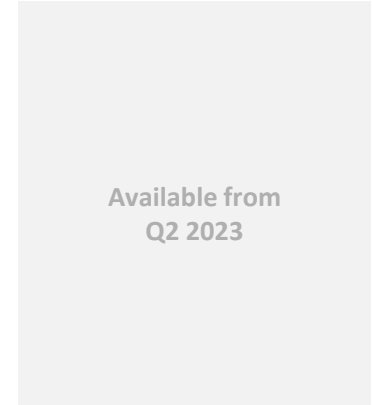

Mobile Charger
88 – 920



Stationary
Backed Charger

A glimpse into the near future of fast charging

- From Q4 2022 Mega-Charger in test operation
- Charging capacity up to 2.4 MW
- Mobile use from 88 kW
input power possible
- New charging plug generation
optional (MCS)
- Available to customers from Q3 2023





VISIT US!

Thank **you**

Designwerk Europe GmbH
Jens Bahrmann
Key Account Manager Europe North
+49 171 430 2095
jens.bahrmann@designwerk.com
designwerk.com

Dora Nordic v/ Rikke Høyer

11.00-11.15



ANDORA

SaaS platform til CO₂ gennemsigtighed
& effektivisering af vejgodstransport

#logtech #climatetech



Hvilke værktøjer har vognmanden i dag?



INTERNATIONALT FRAGTBREV INTERNATIONALER FRACHTBRIEF		GMR	
1 Afsender (navn, adresse, land) Afsender (Name, Anschrift, Land)	[Redacted]		
2 Modtager (navn, adresse, land) Empfänger (Name, Anschrift, Land)	[Redacted] Danmark		
3 Verens leveringssted Auslieferungsort des Gutes	Sted / Ort: Kongens Lyngby Land / Land: DK		
4 Sted og dato for verens overtagelse Ort und Tag der Übernahme des Gutes	Sted / Ort: Land / Land: Dato / Datum:		
5 Vedføjte dokumenter Beigefügte Dokumente	[Redacted]		
6 Mærke og nr. Kennzeichen und Nr.	7 Antal købt Anzahl der Packstücke	8 Emballeringsmåde Art der Verpackung	9 Godsets art Bezeichnung des Gutes
CC	5	Europaller	Gods
			10 Toldkode Zollcode
			11 Bruttovægt i kg Bruttogewicht in kg
			12 Rumfang i m ³ Rauminhalt in m ³

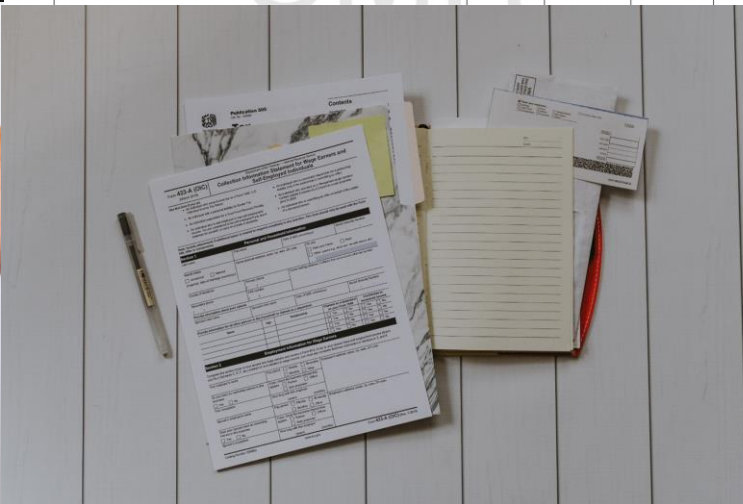



Mere end A til B

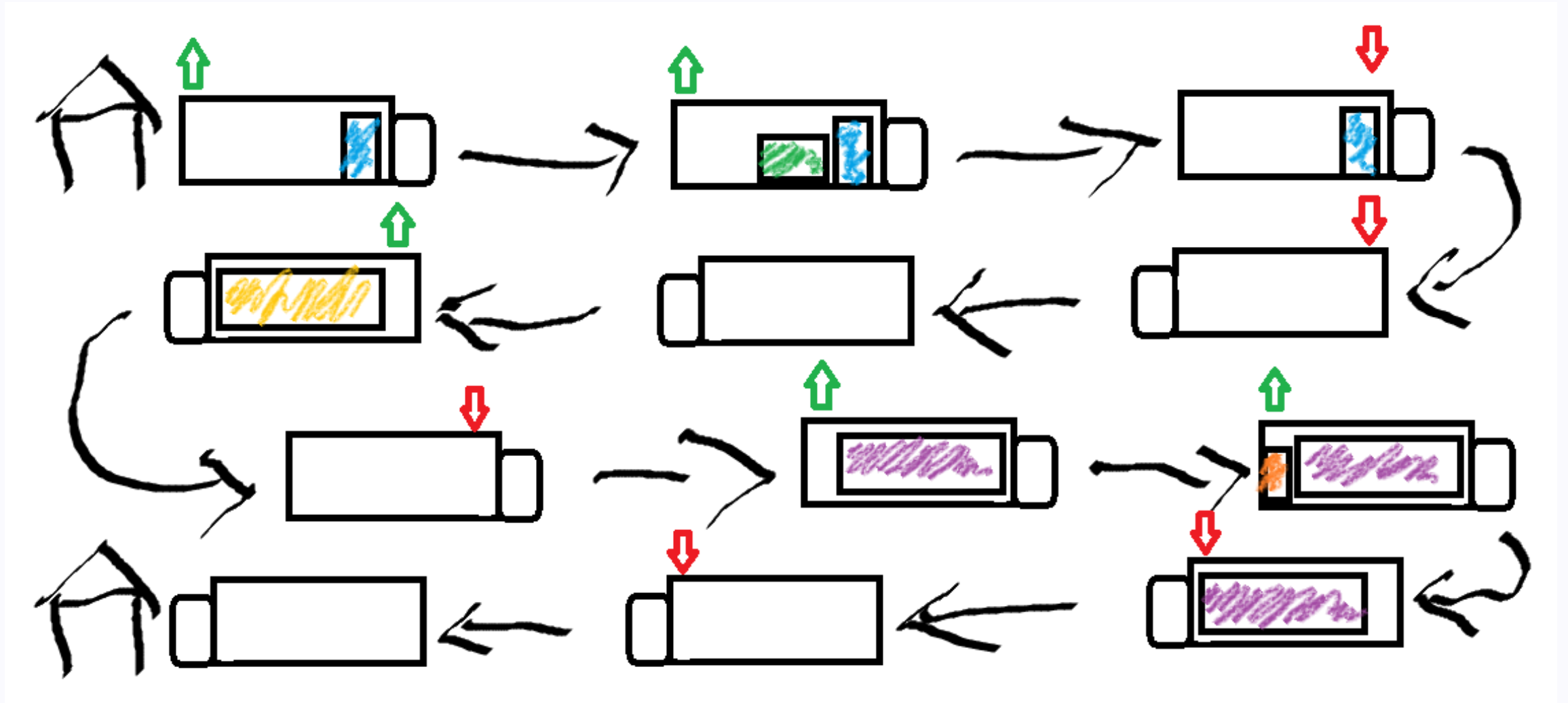



Alt, der kan gå galt, vil gå galt

1. Sending nr. 1 er indleveret til terminal af en samarbejdspartner
2. Sending nr. 2 fylder mindre end booket
3. Bilen skal i vaskehal
4. Tredje sending vejer mere end booket og en anden sending må annulleres
5. Fjerde sending er booket som et fuld læs, men der er alligevel plads til endnu en palle, altså sending 5
6. Bilen kører tom til terminal efter sidste læs er losset

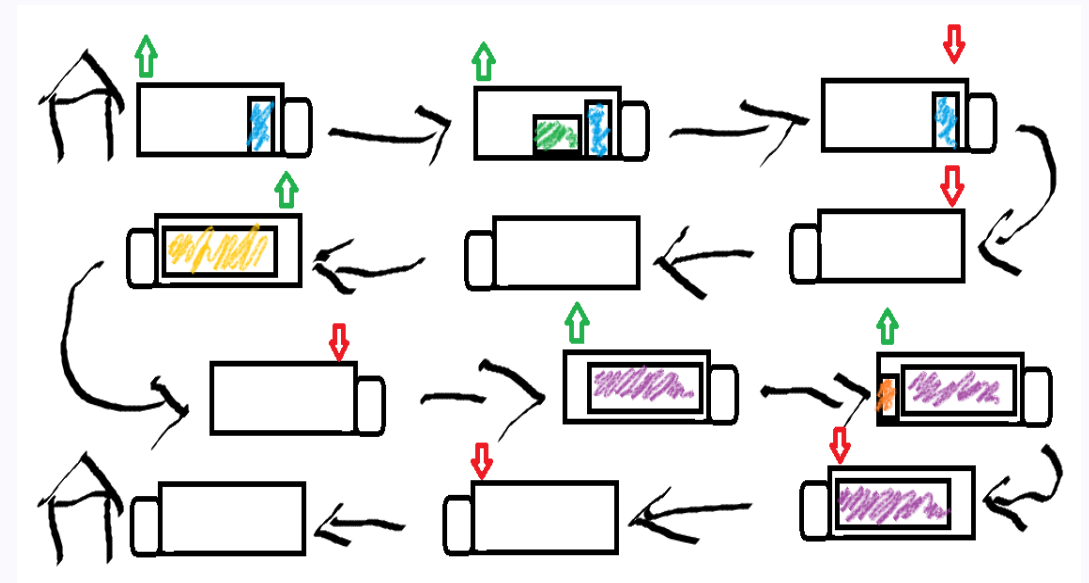



Hvad gør DORA?

INPUT

> CO2

Gns. forbrug km/l
CAN-Bus, tankpåfyldning
Integrationer

> Økonomi

Trailerleje
Leverandører
Kilometerafgift
Brændstof

DORA

> Distancer

Ruteplanlægning, GPS fra bil
og telefon, odometer

> Gods

Fylde, vægt, type

> Trailer + bil

Kapacitet, type, brændstoftype

> Fordeling

Leverandør, kunde, terminaler
eller afvigelser

OUTPUT

> CO2

Transportdeklarationer,
CO2-regnskaber for
transportkøbere og
vognmanden

> Andet

Statistikker, Regnskaber,
forslag til
optimering/alternativer,
baseline/udgangspunkt,
Klimakreditter til grønne
investeringer

ANDORA

Rikke Høyer
rh@doratms.com
+45 28 19 52 19

Pause med dialog ved standene

Nordisk Dialogkonference om nye forretningsmodeller som
understøtter elektrificeringen af erhvervstransporten

VIDEO

11.15-11.30

Hvordan kan vi understøtte elektrificeringen af erhvervstransporten med andre løsninger allerede i dag

v/ Joakim Nilsson, Volvo Trucks

11.30-11.45



Hvordan kan vi understøtte elektrificeringen af
erhvervstransporten med andre løsninger allerede i dag?
Samtale med Joakim Nilsson, Volvo Trucks

Virksomhederne præsenterer deres forretningsmodeller

11.45-12.30



CargoTruckExchange v/ Henrik Larsen

11.45-12.00





Cargo Truck Exchange

Better Payload - Less Air

CargoTruckExchange is a digital platform for the transportation business that helps forwarders to reduce empty kilometers and improve payload

SPEDITØRERNE STÅR OVERFOR EN DIGITAL REVOLUTION

Speditørerne er i et kapløb om at lede den digitale revolution i markedet. Den seneste tid har en digitalisering af samhandlen mellem speditører fået et større fokus da der ligger massive gevinster i at effektivisere denne proces.

DIGITALISERINGEN AF HANDLEN MELLEM SPEDITØRER

Gennemsigtighed i handlen med vogne og gods

- (Bedre beslutningsgrundlag, mindre irrelevant information)

Lavere transportomkostninger

- (Færre tomkilometre, højere kapacitetsudnyttelse)

Lavere administrationsomkostninger

- (Mindre manuelt arbejde, færre menneskelige fejl)

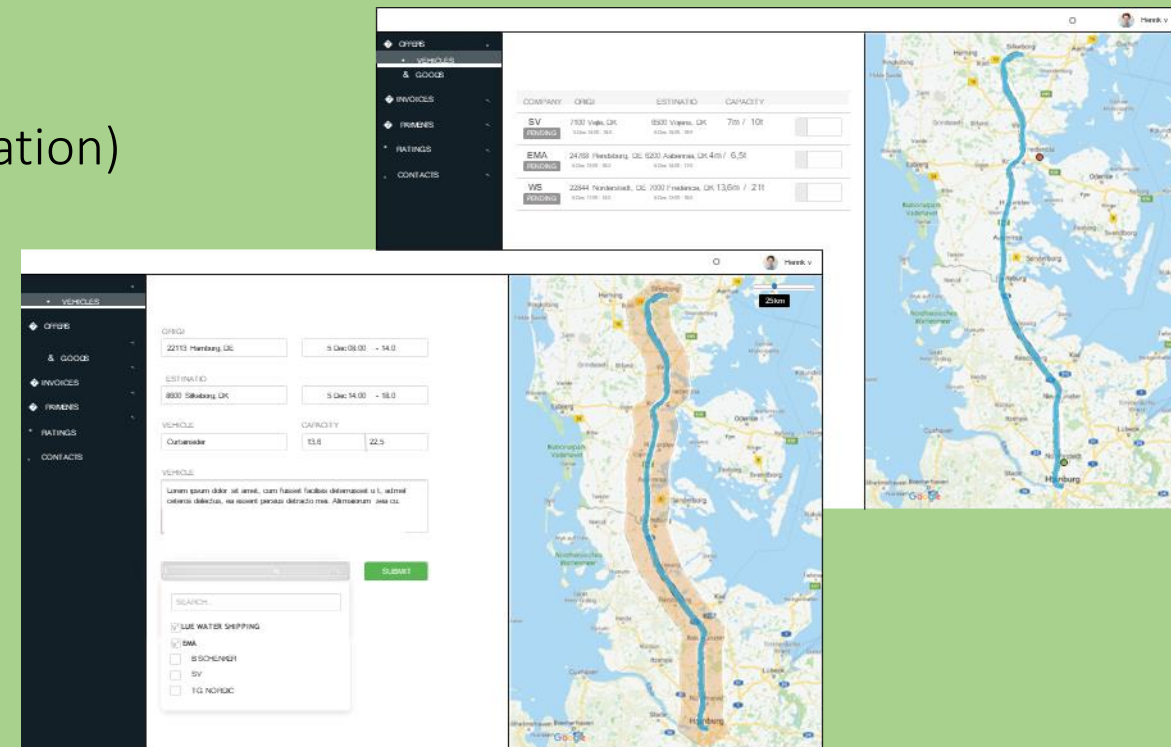

Klimadagsordenen vil udfordre speditørerne

Målet om 70% reduktion af CO2 udledningen vil involvere transportsektoren

”Vejgods- transport udleder tre millioner tons CO2 – eller 5,9% af det samlede udslip i Danmark.”

Og speditørerne har en mulighed for at gøre en stor forskel

”...de 5,9% kan bringes ned til 4,9% ved at reducere tomkørsel fra de opgivne 10% til 5% samtidig med, at man forøger udlastningsgraden fra 12 til 14 tons.”



MANGLENDE GENNEMSIGTIGHED SKABER STORT SPILD

Manglende digitalisering giver et ineffektivt marked med lav gennemsigtighed. Hver 4. kilometer er tomkørsel i Europa. Lastede vogne i Europa har i gennemsnit 43% ledig kapacitet. Der er store muligheder for optimering af økonomien og påvirkningen af miljøet.

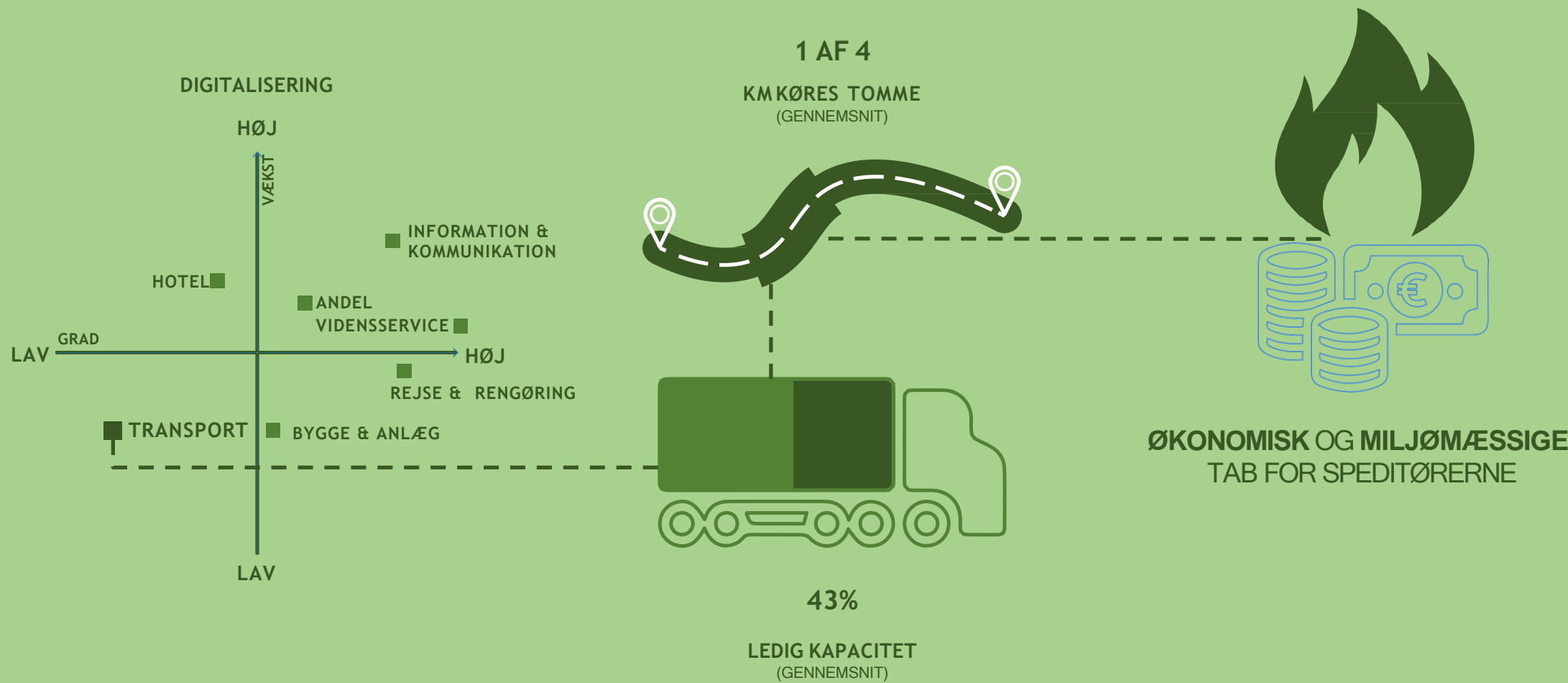

SAAS BASERET PLATFORM SKABER GENNEMSIGTIGHED

En SaaS baseret platform hvor speditøren kan matche sit gods og tomme vogne med sit private eller offentlige netværk vil skabe en hidtil uset gennemsigtighed i markedet

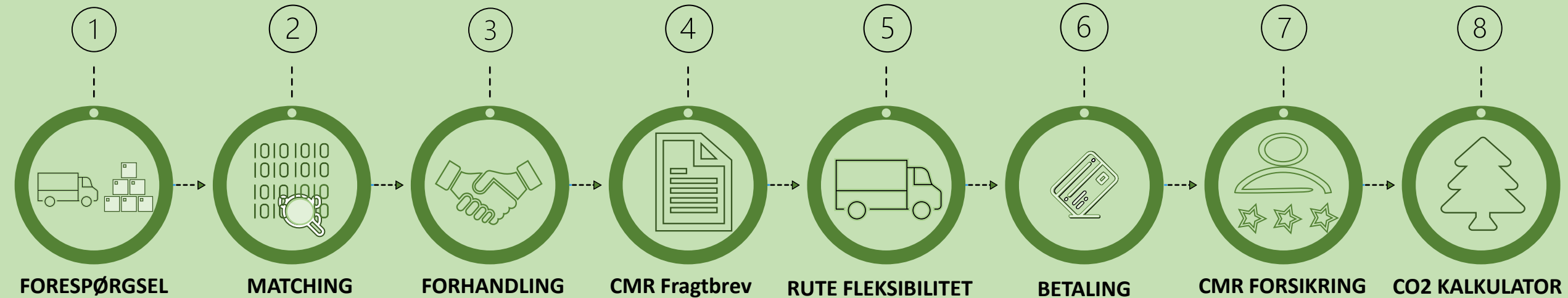

Disponenten efterspørger gods / ledig kapacitet via platformen. Det kan ske automatisk via integration, som sparer tid for disponenten. Det kan også ske manuelt. Alle forespørgsler er anonyme. Det betyder at disponenten ikke eksponerer sin kunde som sales lead.

Vores algoritme matcher udbud og efterspørgsel. Et match af gods og bil udløser en notifikation til de to ansvarlige disponenter. Notifikationen indeholder en prioriteret liste med match for henholdsvis internt, privat og offentligt netværk. Det betyder, at det er nemt for disponenten at vælge det bedste match. Det giver bedre økonomi og nedsat CO2 per ton.

For hvert match er det muligt for parterne at forhandle prisen direkte på platformen. Alle åbne forhandlinger vises sammen, hvilket giver større overblik og mulighed for bedre forhandlinger, som er lig med bedre økonomi.

CMR fragtbrevet kan udveksles automatisk ved match via platformen. Dette gør det lettere og hurtigere for disponenten.

Vores platform viser også gods udenfor rute. Dette giver et udvidet marked, mere fleksibilitet og derved bedre muligheder for at optimere bilen og økonomi, samt for at nedbringe af CO2-udledningen pr. ton.

Platformen tilbyder garanteret og automatisk betaling. Beløbet overføres efter 3 dage til bilejer og trækkes efter løbende måned plus 30 dage fra godsejer. Betalingsservicen inkluderer en standardiseret juridisk proces for fejl. Det betyder ingen inkassoproses og forbedret likviditet. Det sparer tid og udvider markedet.

Alle deltagere på platformen skal uploade deres CMR forsikringspolice på platform. Policen kan ses af de deltagere der ønsker at udveksle gods og biler.

Vores platform kan automatisk levere daglige / ugentlige / månedlige rapporter om den forårsagede CO2-udledning. Det betyder at speditøren kan dokumentere den forårsagede CO2-udledning overfor den enkelte kunde og overfor offentligheden.

ALGORITME AFHJÆLPER MANGE MANUELLE PROCESSER

Matching algoritmen er en væsentlig del af value propositionen til vores kunder; speditørvirksomhederne

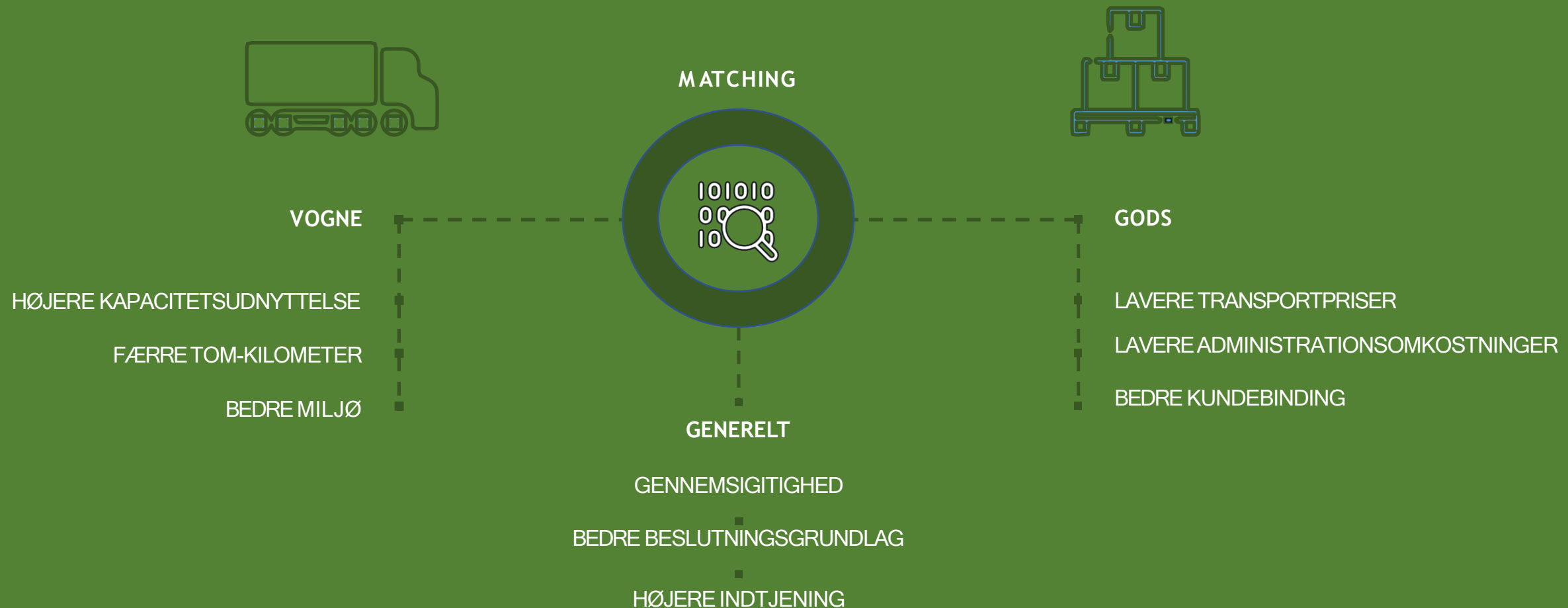

Business case (1) Færre kørt kilometer

Studier foretaget af CargoTruckExchange hos Top5 europæiske speditivirksomheder viser en gennemsnitlig besparelse på 19% på antal kørt km

- Færre tomme km
- Bedre overblik for disponenten da han får bedre overblik

Business Case (2) Administrative besparelser

Tid er penge;

Målinger viser en omkostnings-reduktionen af disponenternes tidsforbrug på **12,5%**

- Tidsstudier udført hos - og tjekket af - to speditorsvirksomheder i Top 5, der benytter TIMOCOM og private netværk (e-mails) når de udveksler biler og gods med andre speditører
- Omfatter tidsforbrug i arbejdet med overskydende gods og biler:
 - Indgående Tilbud
 - Udgående Tilbud
 - Prisforhandling
 - Fakturering
- Baseret på time pris på 520 DKK

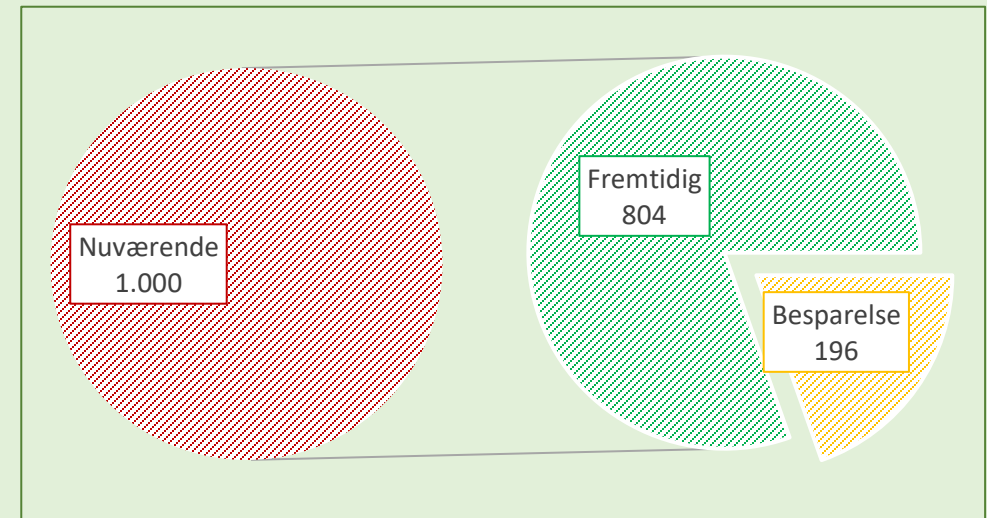

CargoTruckExchange works with networks

We match your remaining goods and vacant trucks with your DFDS colleagues and then with partners and then publicly

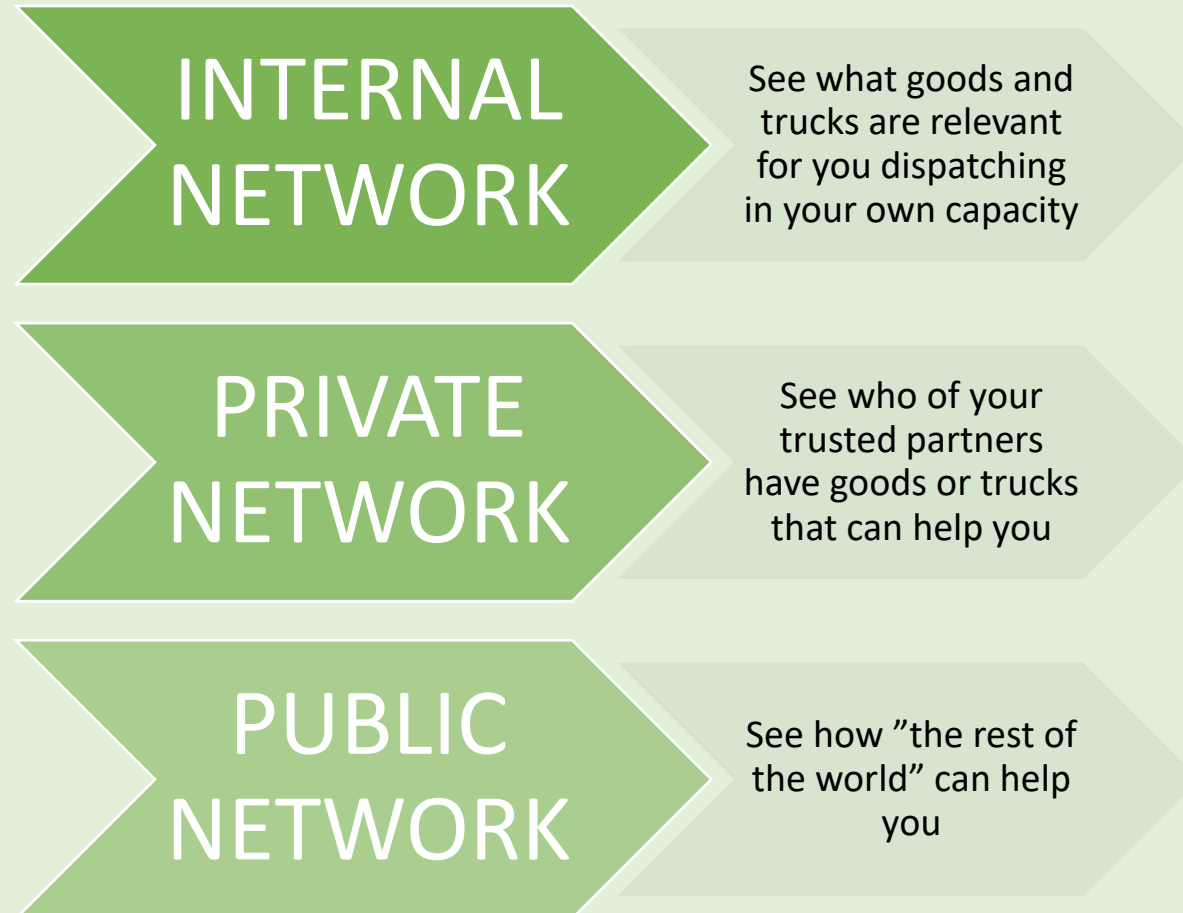

TAK FOR JERES TID

På vegne af CargoTruckExchange teamet



Banke ApS

v/ Janick Cordt Hansen

12.00-12.15



Electrification of commercial transport

Banke ApS

Contact us:

www.banke.pro

marketing@banke.pro

CONFIDENTIAL

No part of this material may be circulated, quoted, or reproduced for distribution without prior written approval from Banke ApS. Any use of this material without specific permission of Banke ApS is strictly prohibited.

Banke's solutions



- Electric power take off (PTO) incl. battery pack
- Electric power take off for battery electric trucks (BEV)
- Drivetrain solutions
- Battery storage solutions

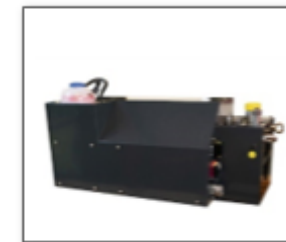

Banke has established a dominant position in the European market for electric power take-offs

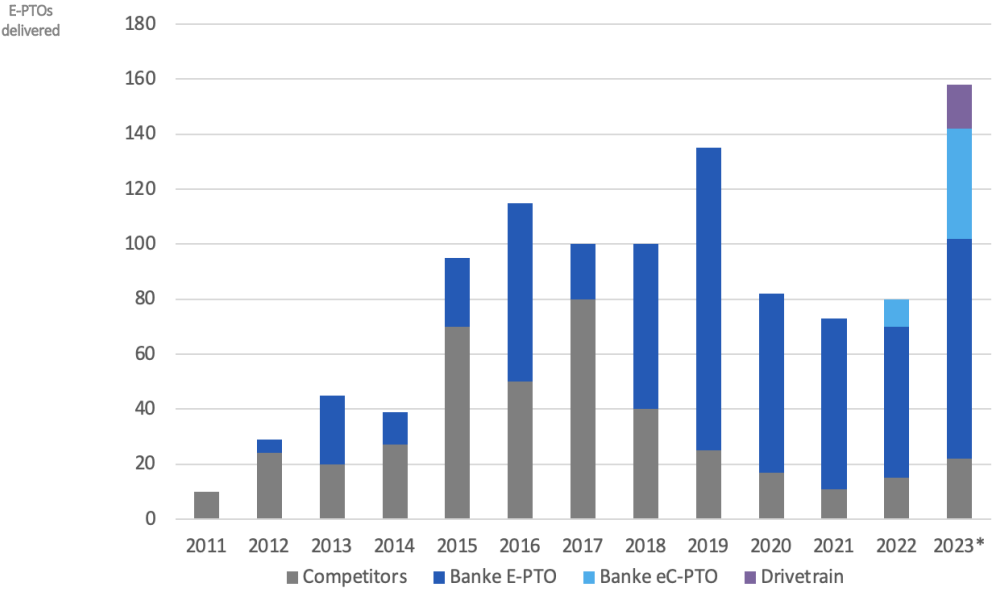

* prognosis

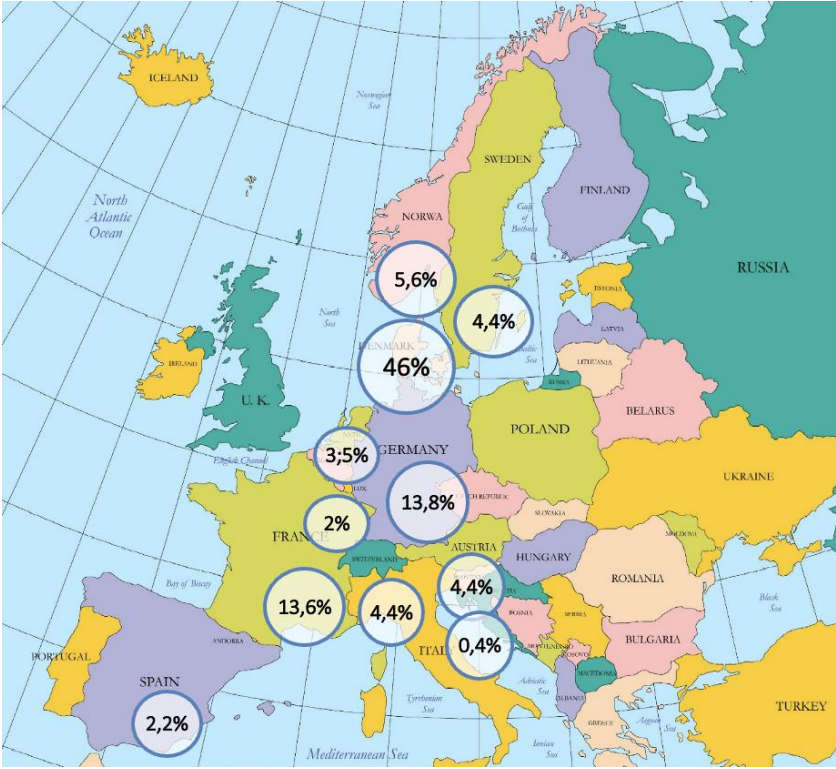

500+ systems in operation in 18 European countries

Banke's solutions

Electric power take off (PTO) incl. battery pack

- Refuse bodies
- Cranes
- Hook-lift e.g.



Top Mounted



Chassis Mounted



System data:

- 115 VDC
- 21, 43, 64 or 86 kWh capacity
- Power 20 to 30 kW continuous
- Charged with CEE 16 Amp fuse
- Delivered with fixed displacement- or variable hydraulic pump



Banke's solutions

Electric power take off (PTO) incl. battery pack Two examples

Euro 6 truck

- Palfinger crane, PK 2120, 20 t meter
 - Hydraulic flow 45-80 l and pressure 340 bar
- CM 43, E-PTO
- Alternator as range extender
- Power 30 kW (continuous)
- Charged with CEE 16, Amp fuse
- I/O control and delivered with variable hydraulic pump with Ls



MB Econic Euro 6 truck

- FAUN refuse body
 - Hydraulic flow 40-120 l and pressure 290 bar
- TM 64, E-PTO
- Power 30 kW
- Charged with CEE, 16 Amp fuse
- I/O control and delivered with variable hydraulic pump



Banke's solutions

Electric power take off (PTO) for full electric trucks (BEV)

- Refuse bodies
- Cranes
- Hook-lift
- Bucket truck e.g.

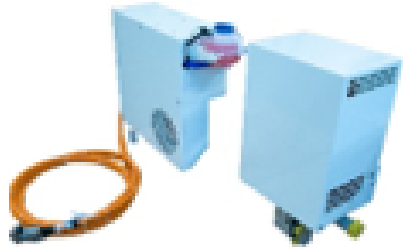

Split version



Single version

Product data:

- 350-700 VDC
- Power between 17 to 60 kW
- CAN communication with chassis
 - DAF, MB Trucks, Scania, BAX and other chassis
- Delivered with fixed displacement- or variable hydraulic pump



Banke's solutions

Electric power take off (PTO) on BEV

Two examples

DAF eCF 6 truck

- 13 ton payload and 220 km range
- Palfinger crane, PK series 24 t meter
 - Hydraulic flow max 130 l and pressure 345 bar
- eC-PTO 30
- Power 30 kW to 45 kW
- I/O control and delivered with variable hydraulic pump with Ls



MB eEconic 6 truck

- 300 kWh battery capacity
- NTM refuse body
 - Hydraulic flow 40-120 l and pressure 265 bar
- Power 30 kW
- I/O control to the body and delivered with variable hydraulic pump



Other solutions



Electric driveline

- ▶ 193 to 386 kWh battery capacity
- ▶ 19000 – 27000 ton truck
- ▶ 614 VDC
- ▶ Power: 190 to 250 kW
- ▶ AC and DC charging
- ▶ Maximum speed 80 km/h
- ▶ IP-grade: IP55
- ▶ According to R100 and other relevant standards



Battery pack for cooling trailer

- ▶ 51 kWh battery capacity
- ▶ 490 VDC
- ▶ LiFePO4 battery cell
- ▶ 2500 cycles full charging cycles
- ▶ Control interface CAN J1939
- ▶ External 11 kW charger
- ▶ Weight: 520 kg

Banke

Contact us:
www.banke.pro
marketing@banke.pro

Uptimus

v/ Magnus Bergkvist Sørensen

12.15-12.30





UPTIMUS

FLEET AS A SERVICE. ELECTRIC. DIGITAL. ALL INCLUSIVE

Hver person, sin egen
operation

Ejerskab = Barrierer

**Ny teknologi =
Usikkerhed og kompleksitet**

“Break down that wall”

Simpelt
Risikofrit
Pris match



Dele vores køretøjer



Fjerne kompleksiteten



Gøre køretøjet digitalt

Dele vores køretøjer



Sign-up

Choose preferred vehicle and location and create subscription



Pick-Up & Drive

Pick-up & Drop-off vehicle at chosen location. All actions via Mobile app



Pay

Payment is done automatically after every finished route

Optimizing Utilization

Example of utilization

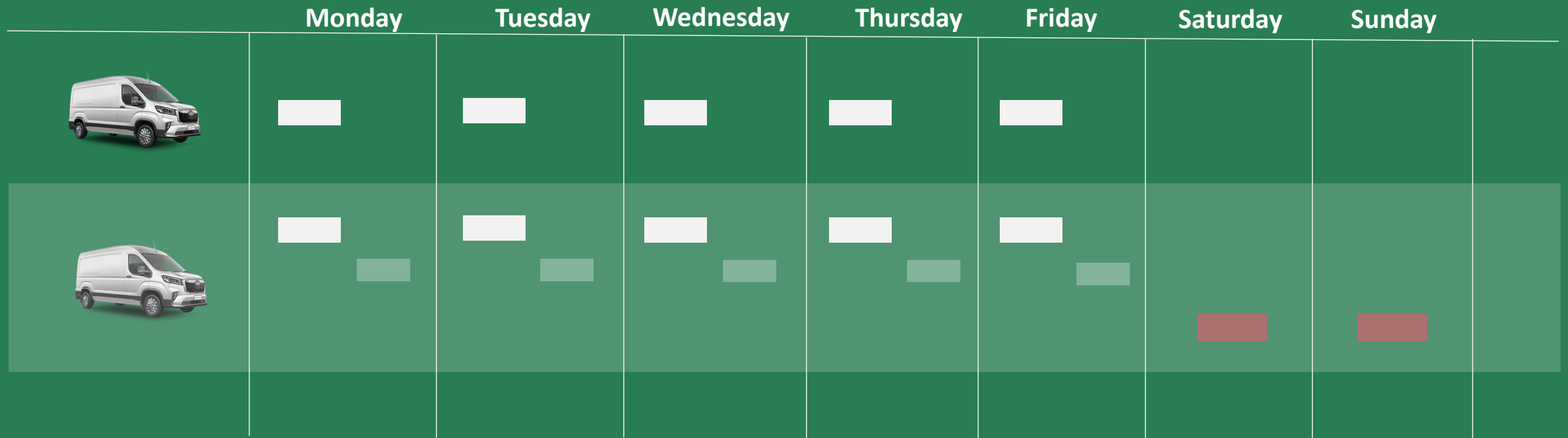

Fjerne kompleksiteten

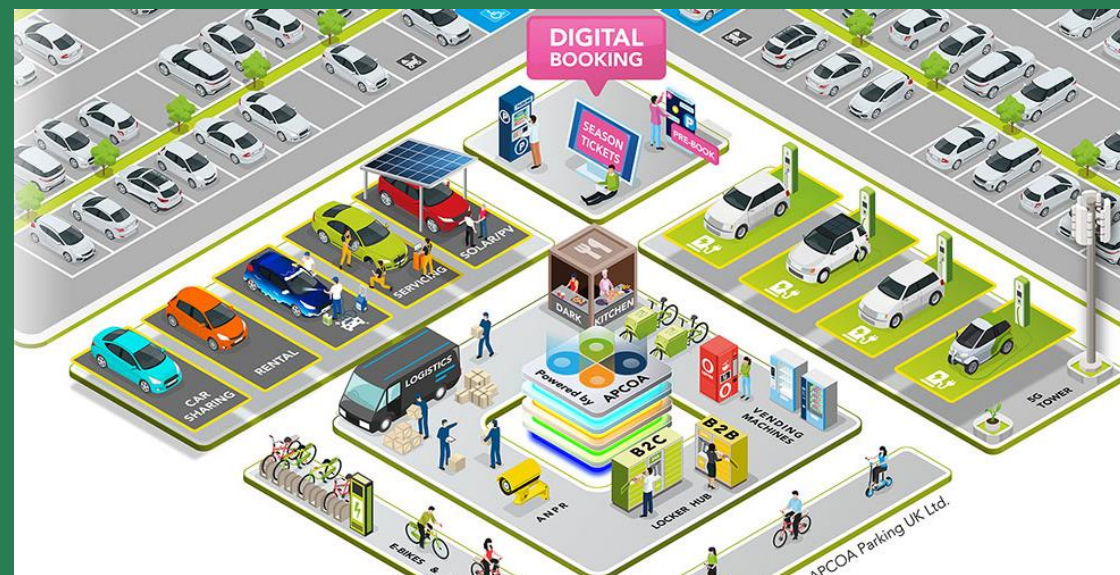
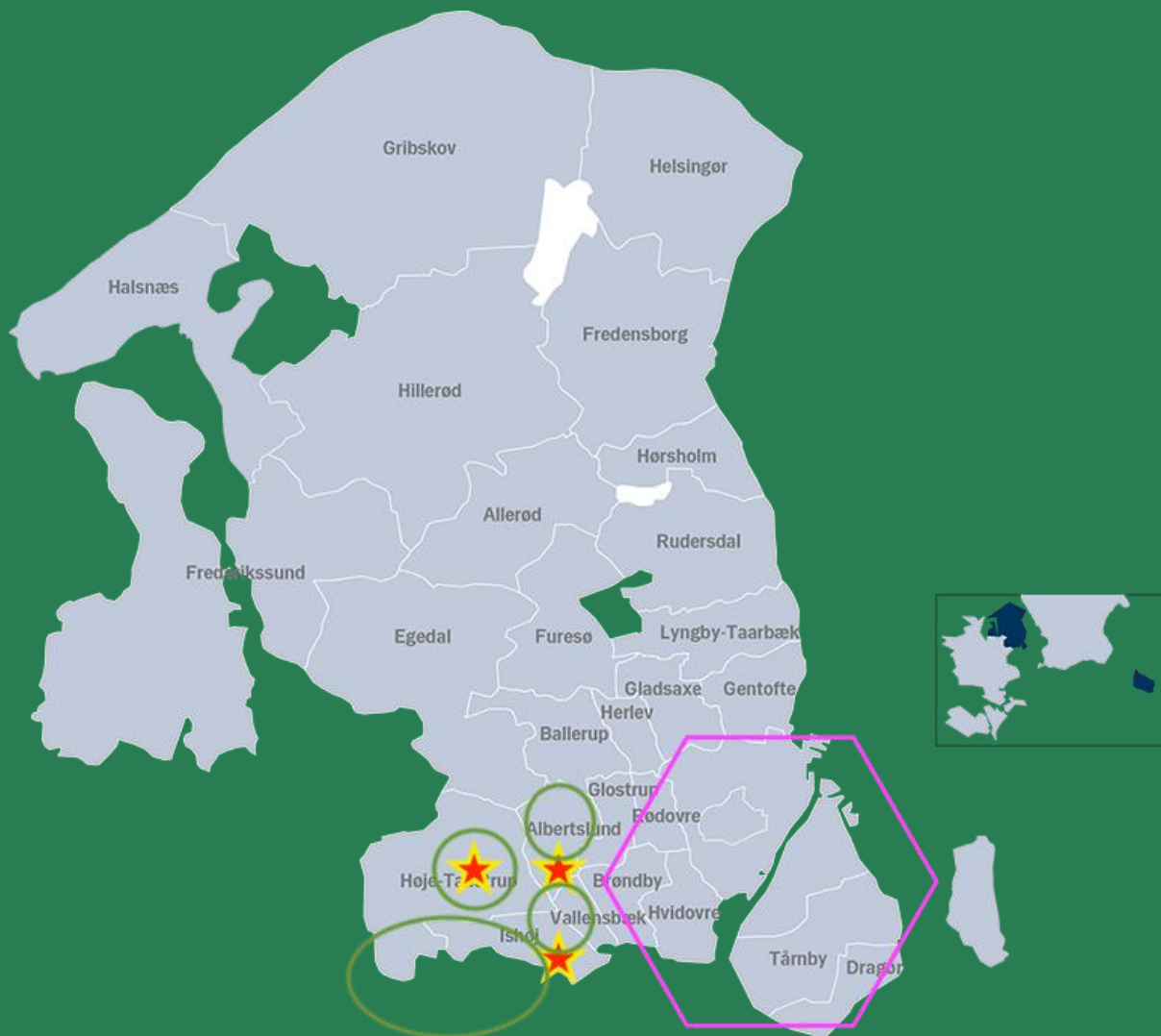

Ladning, Parkering og nem tilgang

Digitalt køretøj



Driver Analysis



**Vehicle
performance**



Pre-Book Charging

Fleet-as-a-Shared-Service



Dele vores køretøjer



Fjerne kompleksiteten



Gøre køretøjet digitalt

En bil ad gangen

Omdrejningspunktet for Forandring

**Fælles Succes gennem
Samarbejde**

Thank You...

Frokost & dialog ved standene

VIDEO

12.30-13.30



Hvordan tænker vi ud af boksen for at få mere grøn omstilling for pengene?

v/ Niels Kristian Holm, Lantmännen Schulstad

13.30-13.40



Hvordan tænker vi ud af boksen for at få mere grøn omstilling for pengene?

Samtale med Niels Kristian Holm, Lantmännen Schulstad



Virksomhederne præsenterer deres forretningsmodeller

13.40-14.30



Nerve Smart Systems

v/ Jens Raarup & George Ivanovic

13.45-14.00





Nerve Smart Systems

NORDIC DIALOGUE CONFERENCE
COPENHAGEN, MARCH 29TH 2023

PRESENTER: JENS RAARUP, CTO

Nerve Smart Systems ApS

Smart Solutions from Electrified People

- Supplier of High-Power Energy Storage & Charging Systems
- Founded in 2016. HQ Roskilde.
- Horizon 2020, EUDP and IFD funded projects.
- Focus segments: Industrial & Manufacturing, Commercial RE, Power Utilities, CPO, among others.
- Nerve Switch® technology. Patented.
- 20 staff
- Administration, Sales & Marketing, R&D, Mechanical Workshop, Prototyping, Pre-production, Assembly & Test.
- B-HPC V1.6 350kW
- Our Value Proposition: High-Power Charging at low cost. No grid constraints. High Profitability & ROI.



Nerve B-HPC v1.6 – Intelligent EV Charging

Selected key benefits



Nerve Switch® 200kWh BESS - 350kW* High Power Charging station

- Multiple revenue streams increase system utilization **secure value creation**, even in low utilization periods.
- Integrated battery system lower grid connection capacity requirement, **reducing installation time and cost**, enabling locations with limited grid capacity.
- Unique battery cell management enable high power output on limited grid capacity and increase battery system lifetime and lower **total cost of ownership**.
- Compact and single module design offers flexibility in placement and **easy relocation**, which makes it perfect for leased land sites and as security against financing.
- Battery chemistry chosen to **eliminate fire hazard**
- Increase grid companies' flexibility reserve needed to safely integrate renewable assets, EV chargers, heat pumps etc., thus **supporting the green transition!**

Nerve Smart Systems B-HPC System Block Diagram

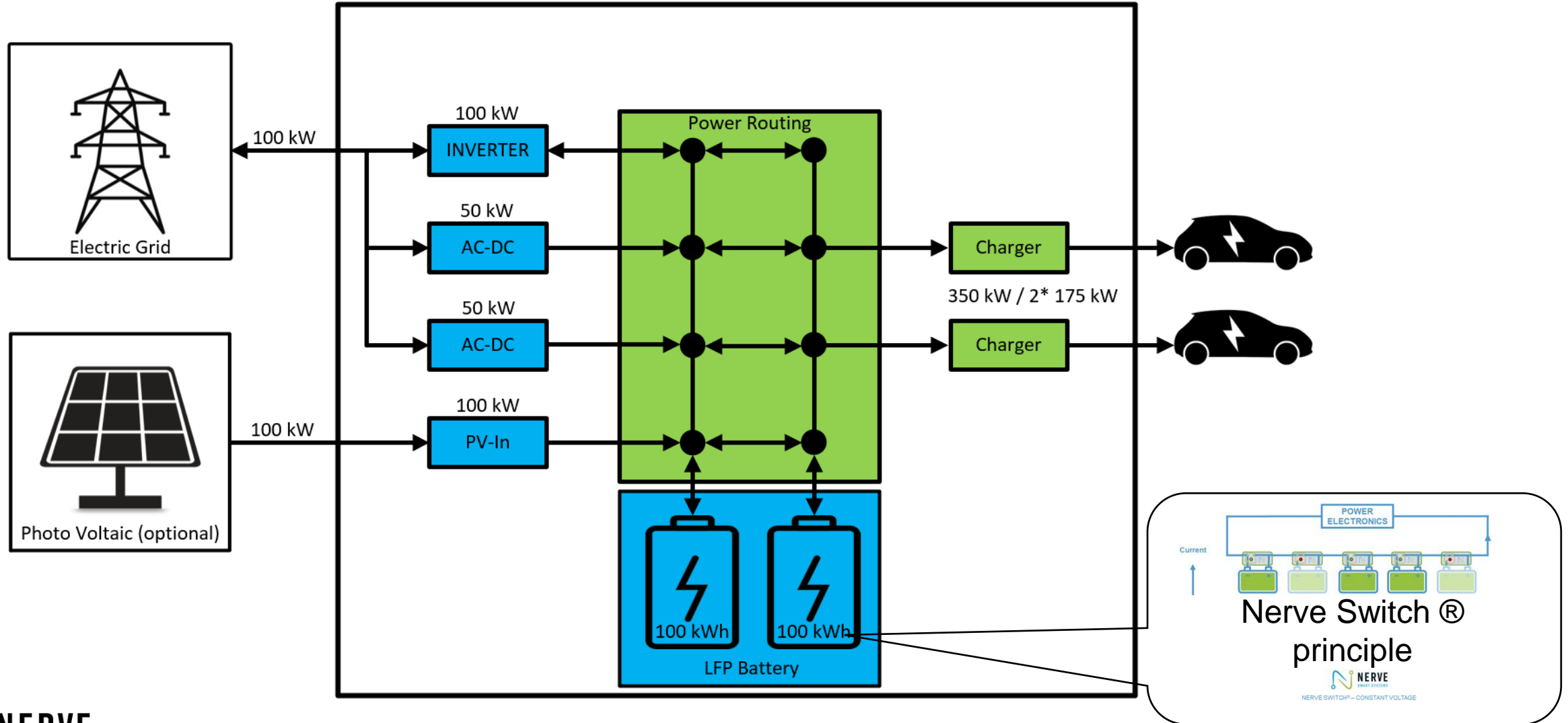

FAB – Feature Advantages Benefits

- FAB - Which system features does the B-HPC system have, how do they translate into advantages and what does the advantages mean for you in terms of tangible benefits (DKK)?

Features	Advantages	Benefits
Battery Energy Storage enabled.	Can be integrated with pre-existing DER (e.g. PV, wind, heat pumps etc.)	Maximum exploitation of your energy asset. Improved ROI.
High-Power charging regardless of the potential grid-constraints.	Can be integrated with any power grid, i.e. without any specific requirements towards the grid in terms of power output.	Low cost integration. Rapid deployment.
Multiple revenue generation streams.	Can generate income 24/7, from EV charging or from the Ancillary service provision.	High return on investment (ROI). Maximum profit throughout the lifetime of the asset.
Mobile unit.	B-HPC can easily be disconnected from the grid and relocated to another physical location (forklift, truck).	Low risk. You can bring your asset with you. The grid connection investment will not be wasted. The mobile aspect makes the system eligible for the financial lease.
Smart Switch® technology enables superior battery management.	High resilience. The system can (almost) not break down as the potential defect battery cells can be bypassed.	High uptime. Low cost of service & maintenance.

Case study* – Behind the meter consumption. PV + EV Charging + Ancillary

*Based on a real customer case with a distribution services company.

1. Maximizes the utilization coefficient of the renewable energy generators (PV, wind e.g.), incl. the financial returns (DKK).
2. Lowers the cost of grid connection.
3. Revenue generation through Frequency Regulation Services to Power Utilities. Frequency Containment Reserve, FCR (D).
4. Energy Time Shifting. Buy energy when cheap and store. Use when expensive.
5. Deployment Speed → Competitive advantage.
6. Relocation possible. Investment in grid connection will not go to waste in case you move to another address.
7. OpEx off Balance Sheet financing possible. Low start-up cost.
8. **ROI 12-18 months!** The ROI sensitive to Ancillary consumption.

10-30% increase

Saves up to 500kDKK

Yearly income up to 150kDKK

10-50kDKK est.

From 18+ months, down to Days

Take your investment with you

Low risk. Low financial exposure.

What's not to like?

Contact information

George Ivanovic

Chief Commercial Officer



Nerve Smart Systems ApS

Langebjergvænget 19A

DK-4000 Roskilde

Ph. +45 5210 7261

Mail: giv@nervesmartsystems.com

www.nervesmartsystems.com



Vialumina

v/ Pontus Frohde & Patrik Lindergren

14.00-14.15





VIALUMINA

Digital Fleet Systems

We make commercial fleets profitable and sustainable

Patrik Lindergren
Pontus Frohde



Connecting



Optimizing

Electrifying

Vialumina in short

Members of: **CLOSER**



DRIVE SWEDEN

Microsoft for Startups



POWER CIRCLE
Electricity for sustainable energy



- Vialumina was founded in 2020 by two former EV-Charging veterans sharing a vision of creating profitable and sustainable fleets
- Our **Fleet Operating System** is based on collecting and processing data to increase efficiency and minimize CO2 emissions for commercial vehicles
- We have built our own software platform and are already serving customers within construction, installation and service, company car fleets, couriers and microfleets
- Offices in Stockholm and Norrköping with a team of 15 people



Target Group – Commercial Fleets

- Construction Fleets
- Service Fleets
- Transport & Courier Fleets
- Corporate Fleets
- State owned Fleets
- Taxi & Car Rental Fleets



According to the latest statistics Europe has around 60M Commercial Vehicles

Ruben Larsson's Haulage & Delivery Company

About the business

A family-owned haulage and delivery company in Östergötland, Sweden with strong local roots.

Run since 2020 by Ruben Larsson who then took over from his father Göran Larsson.

The company has had good growth and profitability up to and including 2021.

Founded: 1976

Based in: Norrköping and Linköping

CEO: Ruben Larsson

Employees: 41



Revenue and KPI's

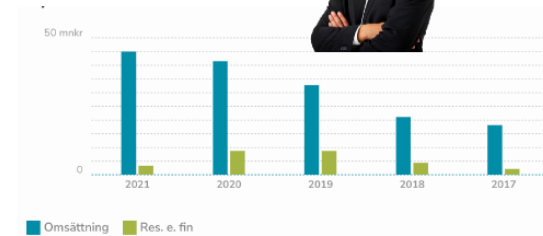

Nyckeltal 2021-12 (tkr)

Omsättning:	45 019	↑
Res. e. fin:	3 365	↓
Årets resultat:	2 560	↓
Summa tillgångar:	30 973	↑

Customers



postnord



Jetpak

IKEA®

Vehicle Fleet

VOLVO Trucks



SCANIA

DAIMLER TRUCK

IVECO



Mercedes-Benz

Total number of vehicles: 65

Heavy Trucks: 15

Light commercial vehicles: 48

Passenger cars: 2

Diesel vehicles: 57

Electric vehicles: 8

Targets 2030

- 10M€ in turnover
- The regions leading "Last Mile" company
- 100% fossil free

Challenges

- Analogous processes lead to a lack of efficiency and control putting pressure on financials
- Today's system support consists of Excel and Post-it notes
- 7 different provider systems that interact with the drivers
- Significantly higher fuel costs (diesel)
- The driver shortage creates new demands on the employer
- The requirements for emission reporting are increasing
- Fossil-free zones in city centers
- Range & charging anxiety

Ruben Larsson's customer journey with Vialumina

Evaluation

- We collect data from all vehicles and create a fact-based electrification report
- Time period 3-6 months
- Ruben chooses to follow the recommendations that emerged in the report and continue his electrification journey
- During the evaluation, Ruben also gained access to the full functionality of Vialumina's system support - he now chooses to sign a running subscription

Monitor & Reporting

- All information about all of Ruben's vehicles is now gathered in one place with a full review, statistics and reports in real time
- The drivers interact and communicate via the app as a tool
- Emission reporting takes place automatically per vehicle
- Ruben can follow the profitability per vehicle as well as information about how the vehicle has been driven and its position
- Anna, who works at Ruben's accounting firm, has a new tool to support Ruben's business with reports and accounting

Fleet Intelligence

- The system monitors values and trends and comes up with ongoing suggestions for improvements based on AI and Machine Learning
- Delivery fees and other costs are integrated directly into the business system
- Decision support system to create increased profitability and feedback to rolling operations
- Ongoing support for environmental reporting and active action programs
- Provides active control and feedback to both transport management and driver

Resource Asset Management

- The charging of Ruben's electric vehicles is automatically optimized and scheduled taking into account the status of the battery, electricity price, available power and needs before the next shift
- Real-time planning and financial resource management of petrol, diesel and electricity in the vehicle fleet.
- New sources of income linked to the car's battery are integrated and followed up

Customer Values

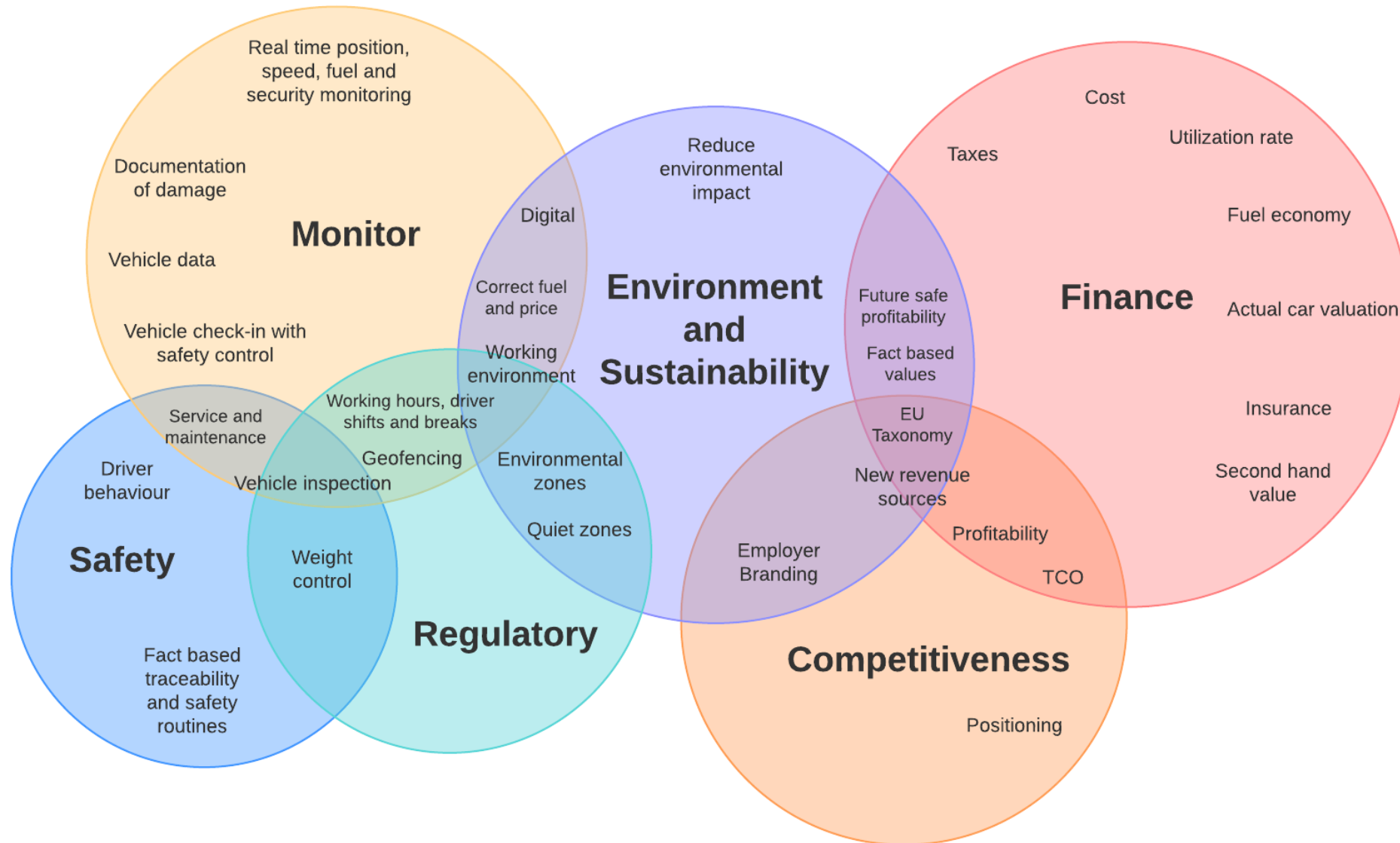



VIALUMINA

An e-logistics company

Contacts

Pontus Frohde

pontus.frohde@vialumina.se

070-959 36 51

Patrik Lindergren

patrik.lindergren@vialumina.se

073-543 33 61

Einride

v/ Carl Ceder

14.15-14.30





Rethink shipping

A new ecosystem for shipping based on **digital, electric and autonomous.**

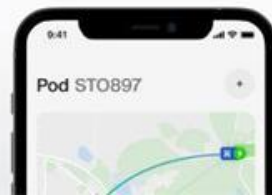
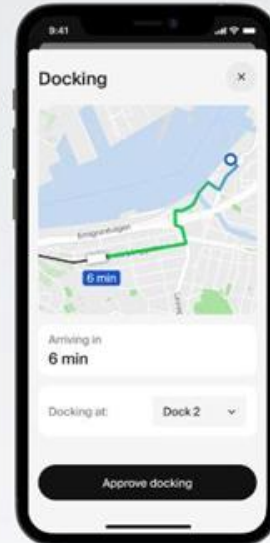
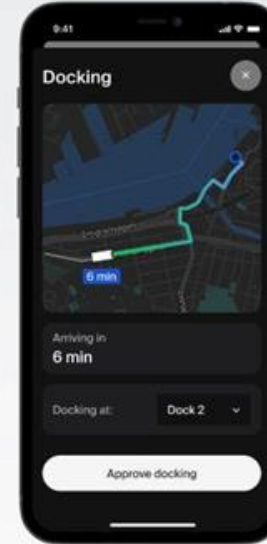
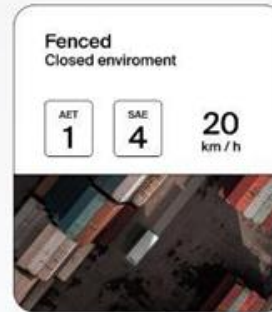

Opsamling & tak for i dag

V/ Christina Bech Godskesen Andersen,
Copenhagen Electric / Region Hovedstaden

14.30-14.35



Kaffe & kage med dialog ved standene

Nordisk dialogkonference om nye forretningsmodeller som understøtter elektrificeringen af erhvervstransporten

-Tak for i dag, slut på programmet!

14.35-15.00